

Small Aperture BPM to Quadrupole Assembly Tolerance Study ¹

Tim Montagne
Stanford Linear Accelerator Center
2575 Sand Hill Road
Stanford, CA 94025

Table of Contents

1.0	Abstract.....	2
2.0	Introduction.....	2
	Figure 1 SA BPM-Injector Quadrupole Assembly.....	2
	Figure 2 BPM Shim to Pole Tip Relationship.....	3
3.0	BPM and Quadrupole Dimensions.....	3
	Figure 3 Critical Dimensions.....	3
4.0	Injector Quadrupole – SA BPM Dimensions and Tolerances.....	4
	Table 1 BPM Dimensions and Tolerances.....	4
5.0	SA BPM Electrodes Center Axis Position Uncertainty.....	4
	Figure 4 Electron Beam Z-Axis to BPM Electrode Center Axis Radial Tolerance.....	5

¹ Work supported in part by the DOE Contract DE-AC02-76SF00515. This work was performed in support of the LCLS project at SLAC.

1.0 Abstract

The LCLS injector and linac systems utilize a series of quadrupole magnets with a beam position monitor (BPM) captured in the magnet pole tips. The BPM measures the electron beam position by comparing the electrical signal from 4 electrodes and interpolating beam position from these signals. The manufacturing tolerances of the magnet and BPM are critical in determining the mechanical precision of the electrodes relative to the nominal electron beam Z-axis. This study evaluates the statistical uncertainty of the electrodes center axis relative to the nominal electron beam axis.

2.0 Introduction

The injector SA BPM is positioned in the quadrupole as shown in Figure 1. The BPM is located by the 4 magnet pole tips, capturing a cylindrical shim which in turn clamps the BPM. A statistical tolerance for the BPM electrode positions can be determined from the manufacturing tolerances of the individual components.

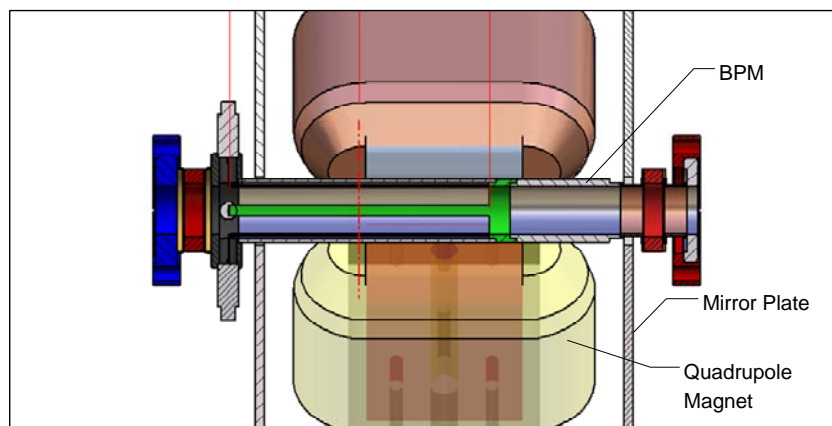

Figure 1 SA BPM-Injector Quadrupole Assembly

The pole tips of the quadrupole magnet capture a cylindrical shim that clamps the BPM firmly in the center of the four magnet pole tips. This is illustrated in Figure 2.

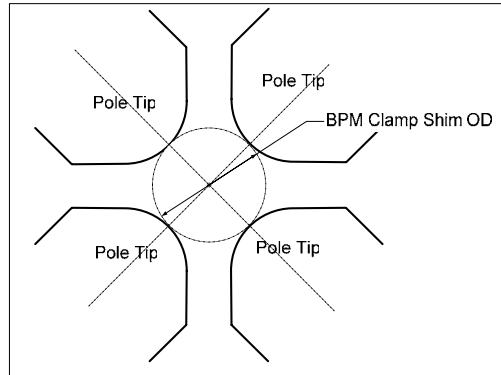

Figure 2 BPM Shim to Pole Tip Relationship

The uncertainty of the BPM position in the quadrupole magnet is calculated based on the manufacturing tolerances of the BPM, shim, and the magnet.

3.0 BPM and Quadrupole Dimensions

The critical dimensions defining BPM mechanical position tolerances are illustrated in figure 3.

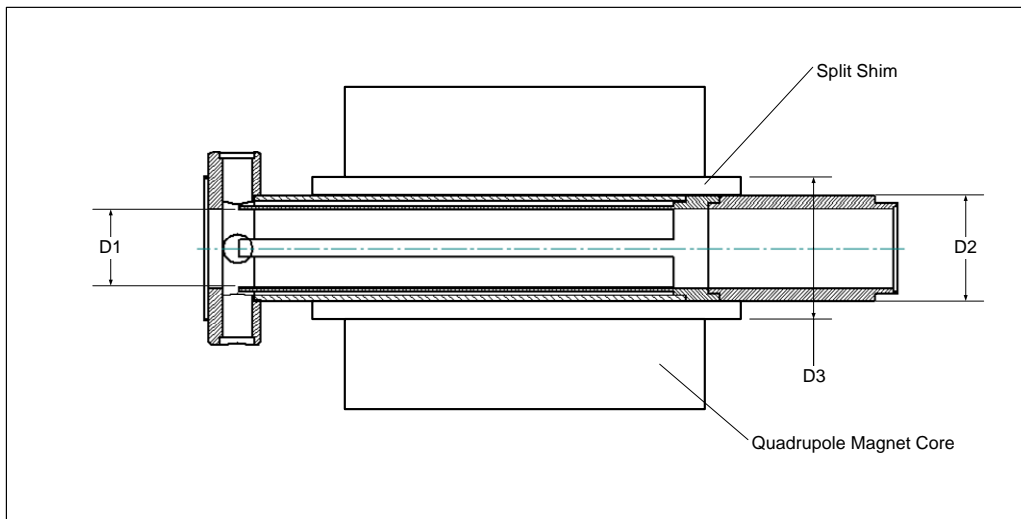

Figure 3 Critical Dimensions

4.0 Injector Quadrupole – SA BPM Dimensions and Tolerances

The dimensions and tolerances for the injector SA BPM, quadrupole magnet, and BPM mount shim are listed in table 1. These dimensions are tabulated from manufacturing drawings of the SA BPM and the quadrupole magnet specification².

Dimension Description	Nominal Dimension		Tolerance	
	inches	mm	Inches	μm
D1 Electrode ID	.870	22.098	±.001	±25.4
d _{1a} diametral tolerance			±.001	±25.4
d _{1b} runout tolerance	-	-	.002	±50.8
D2 BPM Body OD	1.160	29.464		
d _{2a} diametral tolerance			±.005	±127
D3 Pole Tip ID	1.260	32.000		
d _{3a} runout			.002	±50.8

Table 1 BPM Dimensions and Tolerances

5.0 SA BPM Electrodes Center Axis Position Uncertainty

The manufacturing tolerances for the quadrupole magnet pole tips, BPM body OD, and the BPM electrode ID can be used to derive a position uncertainty for the BPM Electrodes mechanical center axis, [U_P/P]. The percentage uncertainty is defined by the equation:

$$\frac{U_P}{P} = \sqrt{\left(\frac{d_{1a}}{D1}\right)^2 + \left(\frac{d_{1b}}{D1}\right)^2 + \left(\frac{d_{2a}}{D2}\right)^2 + \left(\frac{d_{3a}}{D3}\right)^2} \quad i$$

² Dimensions tabulated from *ESD 1.2-113 Specification for LCLS Injector Quadrupole Magnets* and SLAC drawing number *SA-380-514-00 LCLS Injector Small Aperture Beam Position Monitor Assembly*.

Substituting the diameter values and their associated tolerances, we obtain an uncertainty of:

$$\frac{U_P}{P} = 0.563 \%$$

Applying this percentage to the nominal electrode ID of .870", we obtain a position uncertainty of:

$$U_D = .0049'' \text{ or}$$

$$U_D = 124.4 \mu\text{m} \text{ (Diametral Position Uncertainty)}$$

The BPM electrodes Z-axis has a radial position uncertainty relative to the nominal beam Z-axis. This defines the electrodes center in a circular tolerance zone around the nominal beam Z-axis described on the X-Y plane.

$U_R = 62.2 \mu\text{m}$

The relationship of these axes is shown in Figure 4.

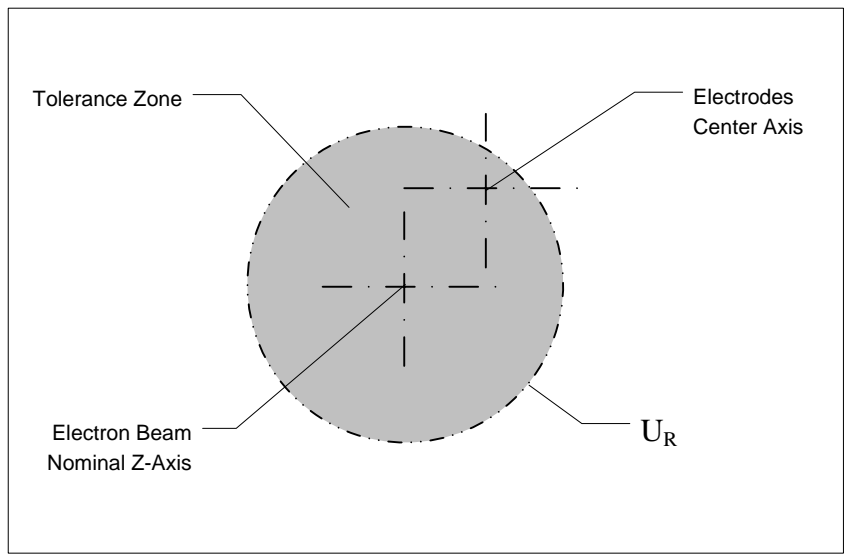

Figure 4 Electron Beam Z-Axis to BPM Electrode Center Axis Radial Tolerance

ⁱ *Mechanical Measurements 5th Edition* Bechwith-Marangoni-Lienhard p. 244