

SC4-Photon Systems-XTOD Physics Requirements

Communications/Coordination for Physics Requirements Development

Physics Requirements Documents (PRDs): Status

X-Ray Beam Line Layout (LCLS/LUSI/Users joint effort)

Preconditions/Features

Operational Overview

Offset Mirror System (an update, and 2nd example of a joint effort)

Current Layout

Estimate of Mirror Effects

Other Factors

Acknowledgments:

X-Ray Beam Line Layout: John Arthur and Jerry Hastings

Offset Mirror System: Mike Pivovarovoff and Peter Stefan

SC4-Photon Systems-XTOD Physics Requirements

XTOD Physics Requirements Documents (PRDs): Current Status

Instrument/Area	PRD Status
XTOD Mechanical/Vacuum	Completed
Gas/Solid Attenuator	Completed
Slits and Fixed Mask	Completed
Gas Detector	Completed
Total-Energy Calorimeter	Completed
Soft X-Ray Offset Mirrors	Draft completed/circulating
Hard X-Ray Offset Mirrors	In preparation
K and Low-Energy Spectrometer	In preparation
Direct Imager (FEE, NEH and FEH)	In preparation
Pop-In Monitors	Not started
Radiation Physics Collimators and Shielding (FEE, NEH and FEH)	(Now working with RP)

SC4-Photon Systems-XTOD Physics Requirements

Beam Line Layout preconditions/features:

All Experimental Hutches to be **accessible**, if not **in use**.

Enable multiple, simultaneous experiments.

Enable quick changeover from one experiment to another.

SC4-Photon Systems-XTOD Physics Requirements

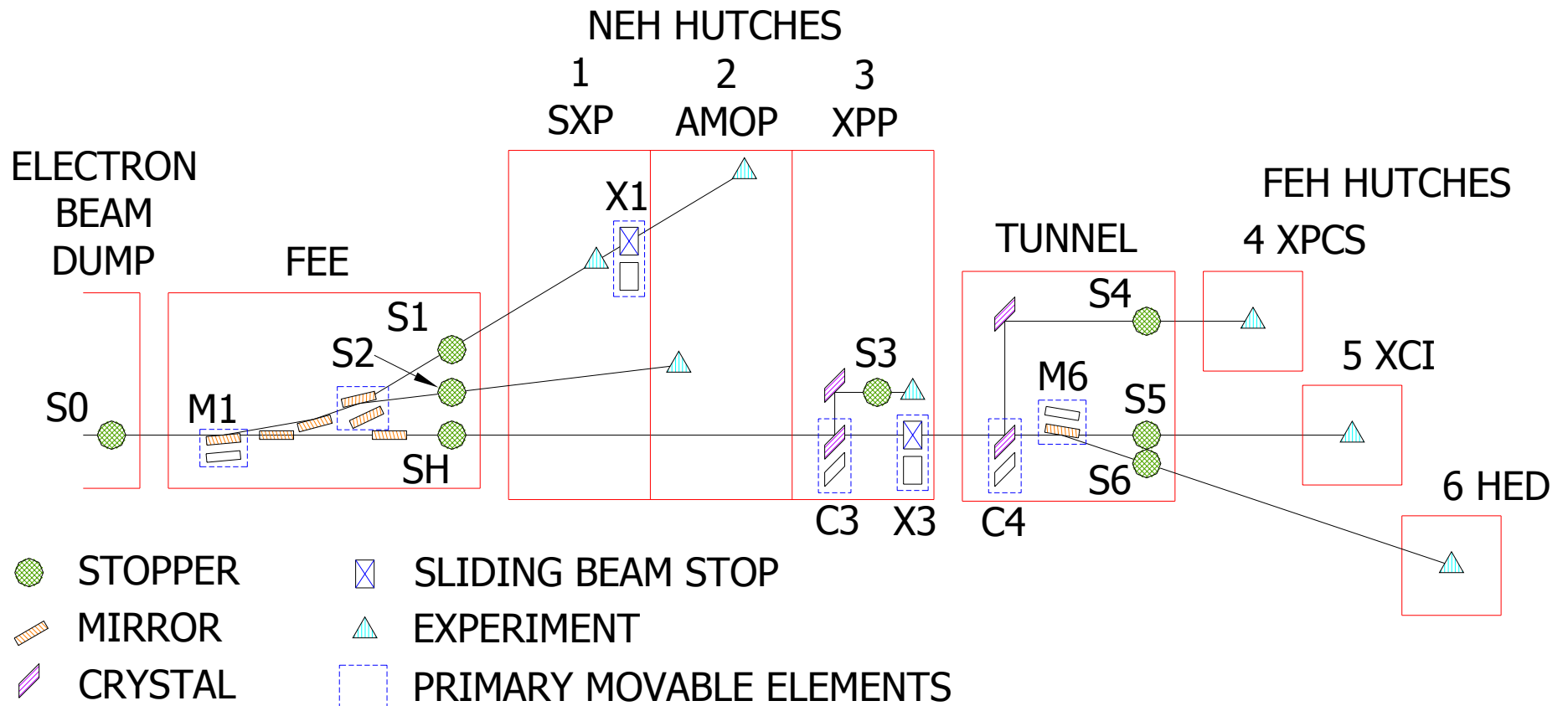

SC4-Photon Systems-XTOD Physics Requirements

Soft X-Ray Offset Mirror System (SOMS):

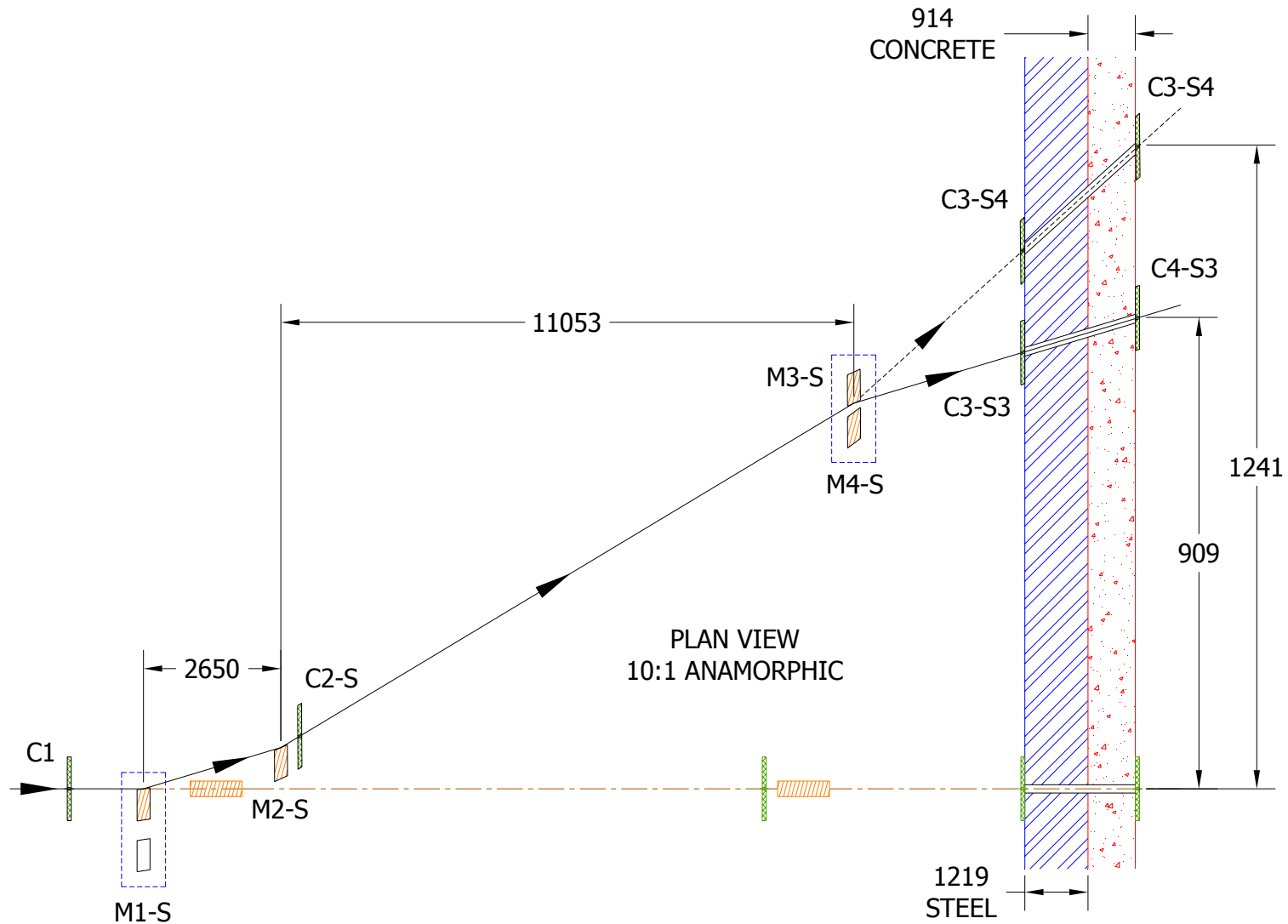

SC4-Photon Systems-XTOD Physics Requirements

Hard X-Ray Offset Mirror System (HOMS):

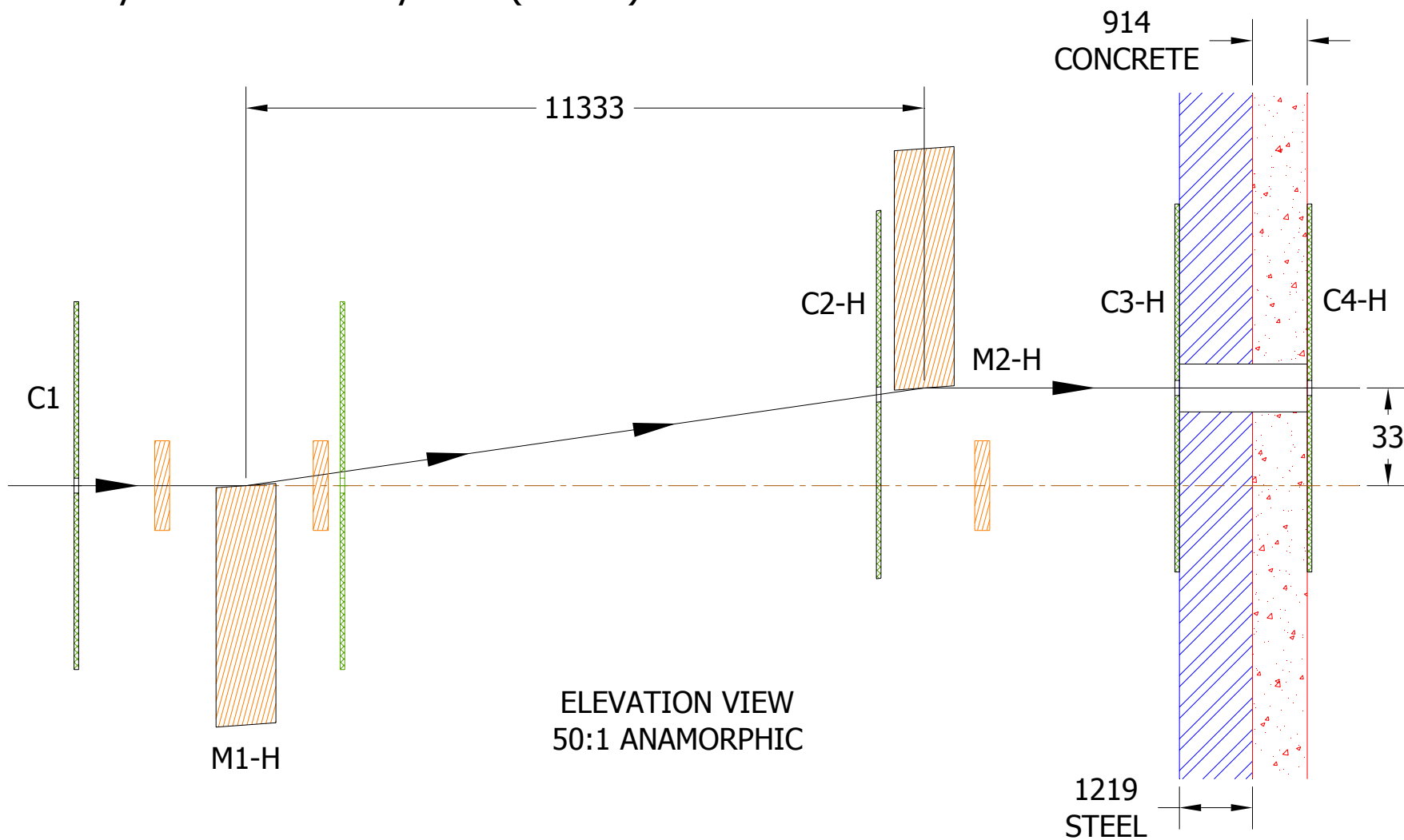

SC4-Photon Systems-XTOD Physics Requirements

Estimate of Mirror Effects:

divergence degradation and scattered photon generation

Use formalism by Gene Church and Peter Takacs:

Specification of Glancing- and Normal-Incidence X-Ray Mirrors, Optical Engineering Vol. 34 No. 2, pp 353-360, 1995.

Prediction of Mirror Performance from Laboratory Measurements, SPIE Vol.1160, pp. 323-336, 1989.

Fractal Surface Finish, Applied Optics Vol. 27 No. 8, pp1518-1526, 1988.

The Optimal Estimation of Finish Parameters, SPIE Vol. 1530, pp. 71-85, 1991.

Specification of Surface Figure and Finish in Terms of System Performance, Applied Optics Vol. 32 No. 19, pp. 3344-3353, 1993.

SC4-Photon Systems-XTOD Physics Requirements

Estimate of Mirror Effects:

Use conservative, fractal, power spectral density (PSD) for mirror errors, based on data from delivered SSRL mirrors:

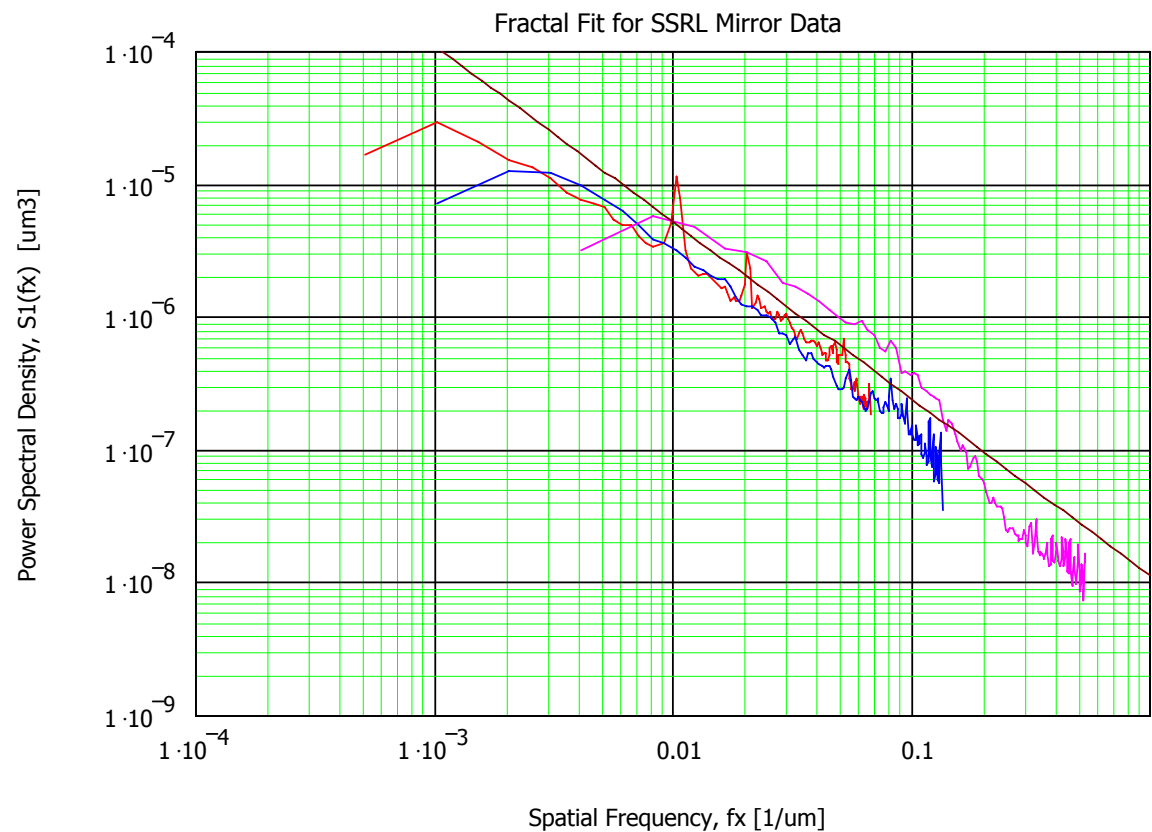

SC4-Photon Systems-XTOD Physics Requirements

Estimate of Mirror Effects:

Assume highly-idealized FEL beam profile, based on Ming Xie description and the diffraction limit:

FEL Condition		FWHM Source Parameters	
λ (nm)	hv (eV)	Size (μm)	Divergence (μrad)
1.5	830	81.6	8.11
0.62	2000	76.0	3.60
0.15	8300	60.0	1.10

A more realistic beam profile is now being calculated by Sven Reiche. Larger effective divergence is likely.

SC4-Photon Systems-XTOD Physics Requirements

Estimate of Mirror Effects:

Attainable mirror Figure errors (slope errors):

From informal vendor conversations:

$\leq 0.25 \mu\text{rad}$ recently delivered for three, 350 mm silicon mirrors.

A 1 m mirror, with a central sub-region figure error of $\leq 0.25 \mu\text{rad}$ should be readily achievable.

But recall: $\leq 0.1 \mu\text{rad}$ will become available for mirrors of the dimensions we require, through deterministic polishing/correction, in the next several years.

SC4-Photon Systems-XTOD Physics Requirements

Estimate of Mirror Effects:

A summary of the results: Scattering and Divergence Increase

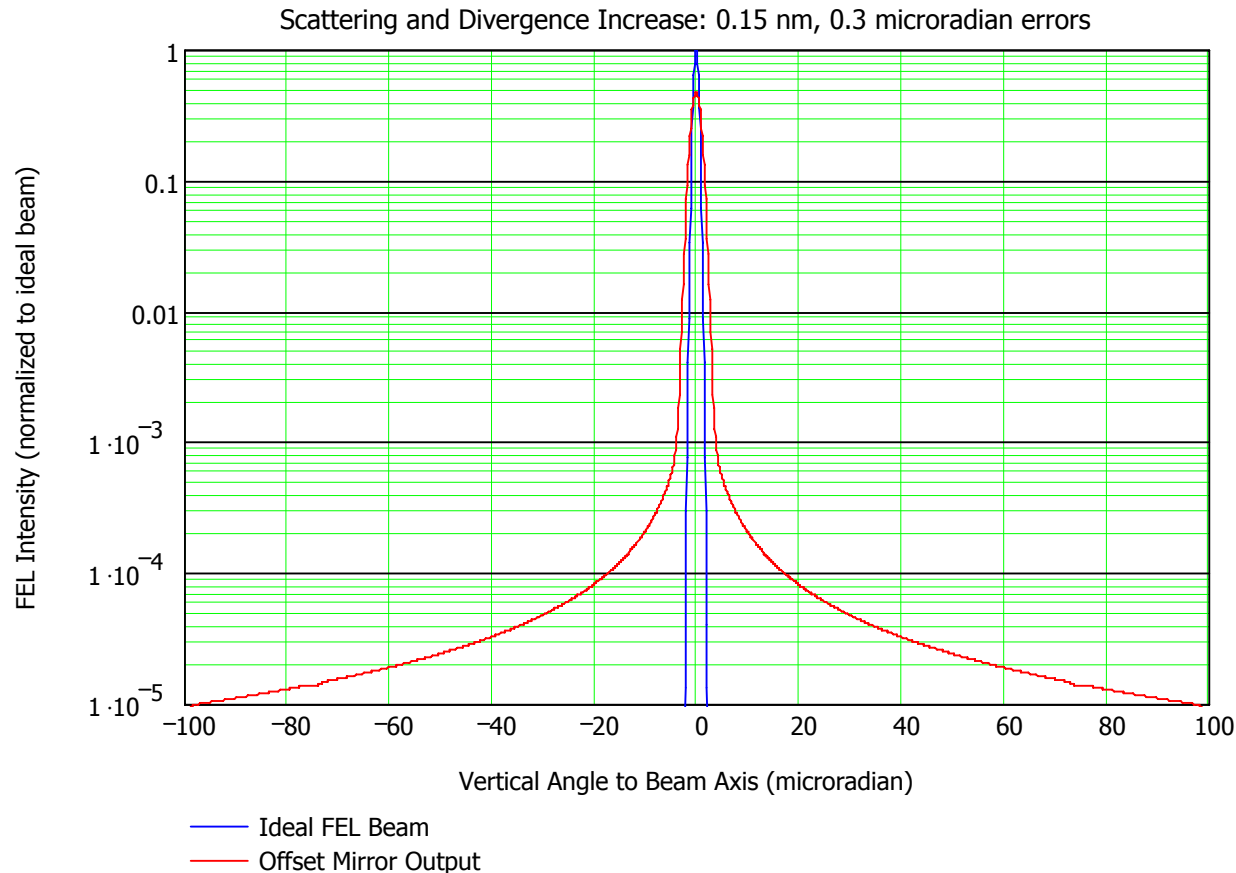

SC4-Photon Systems-XTOD Physics Requirements

Estimate of Mirror Effects:

A summary of the results: **worst-case, FEH Hutch 6**

FEH6: $z = 406.1$ m from downstream end of the LCLS Undulator
 $\lambda_{\min} = 0.15$ nm (8.265 keV)
 $\lambda_{\max} = 0.62$ nm (2.0 keV)

Parameters "Independent" of Offset Mirror System:

Horizontal Axis	λ_{\min}	λ_{\max}
Source Distance (m)	460.4	427.2
FWHM Source Size (μm)	59.94	76.03
FWHM Source Divergence (μrad)	1.10	3.60
FWHM Beam Size in Hutch (μm)	511.8	1539.0

Parameters Dependent on Offset Mirror System:

Vertical Axis	0.3 μrad Slope Errors		0.2 μrad Slope Errors		0.1 μrad Slope Errors	
	λ_{\min}	λ_{\max}	λ_{\min}	λ_{\max}	λ_{\min}	λ_{\max}
Effective Source Distance (m)	379.7	411.8	403.6	419.6	437.3	425.1
FWHM Source Divergence (μrad)	2.29	4.12	1.74	3.84	1.30	3.66
FWHM Beam Size in Hutch (μm)	873.2	1697.1	704.4	1612.1	570.3	1558.2

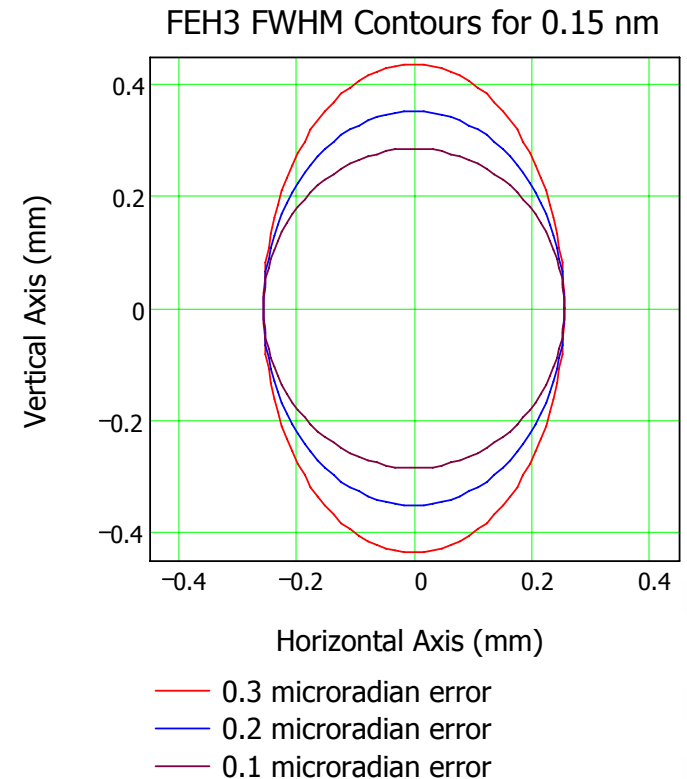

SC4-Photon Systems-XTOD Physics Requirements

Estimate of Mirror Effects:

A summary of the results: in the NEH

NEH2 FWHM Contours for 0.62 nm

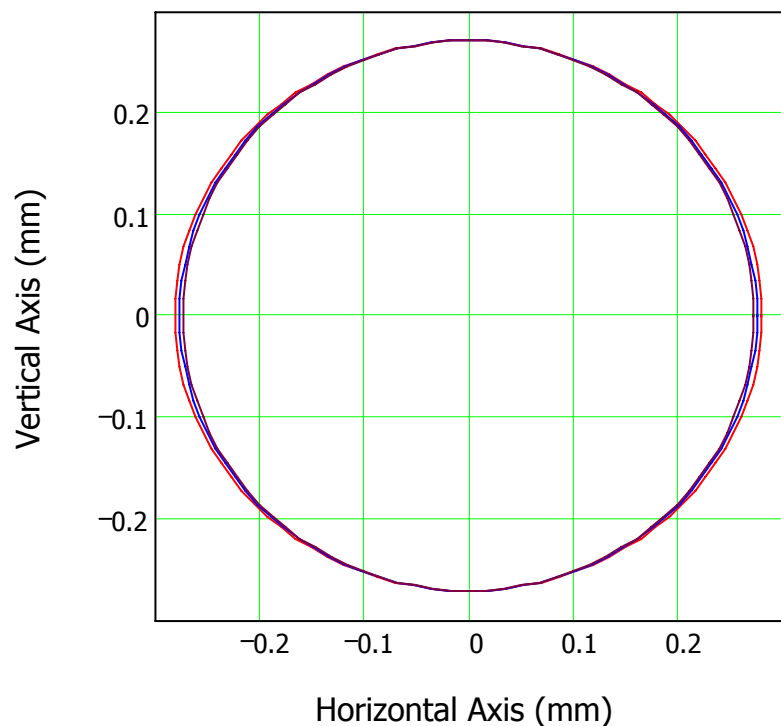

- 0.3 microradian error
- 0.2 microradian error
- 0.1 microradian error

NEH3 FWHM Contours for 0.15 nm

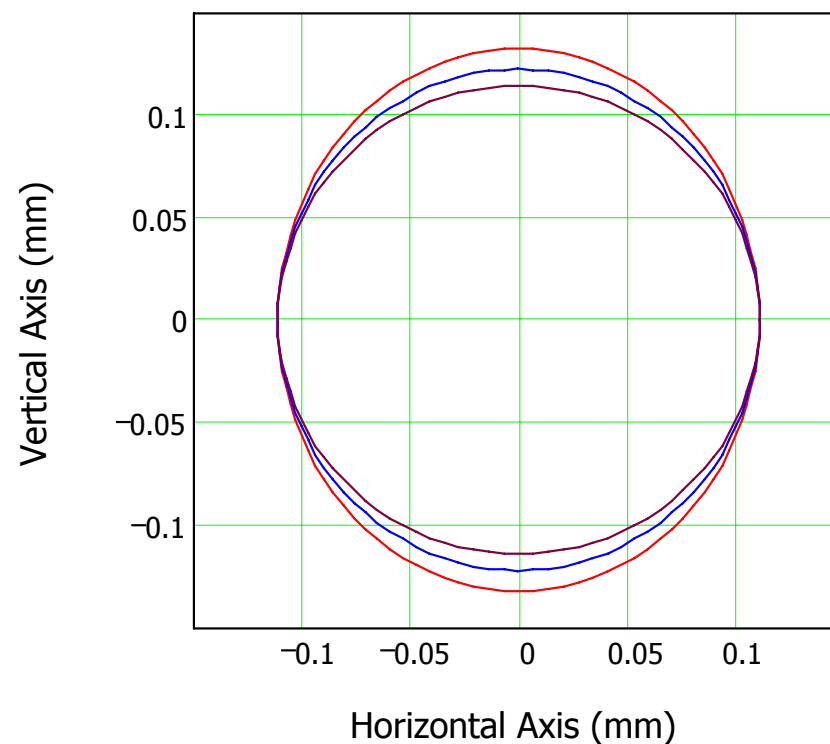

- 0.3 microradian error
- 0.2 microradian error
- 0.1 microradian error

SC4-Photon Systems-XTOD Physics Requirements

Other important factors in the Offset Mirror Systems design:

Pointing Error/Stabilization: $\leq 0.1 \mu\text{rad}$ may be required, to limit motion to less than 1/10 beam size.

Thermal loads and "thermal grounding": thermal drift

Ground/floor vibrations and settling: an intrinsic limit

Beam position feedback stabilization: likely required on HOMS

SC4-Photon Systems-XTOD Physics Requirements

Other important factors in the Offset Mirror Systems design:

Pointing Error/Stabilization:

Ground/floor vibrations and settling: an intrinsic limit

A Traveling Seismic Shear Wave: generates pointing error

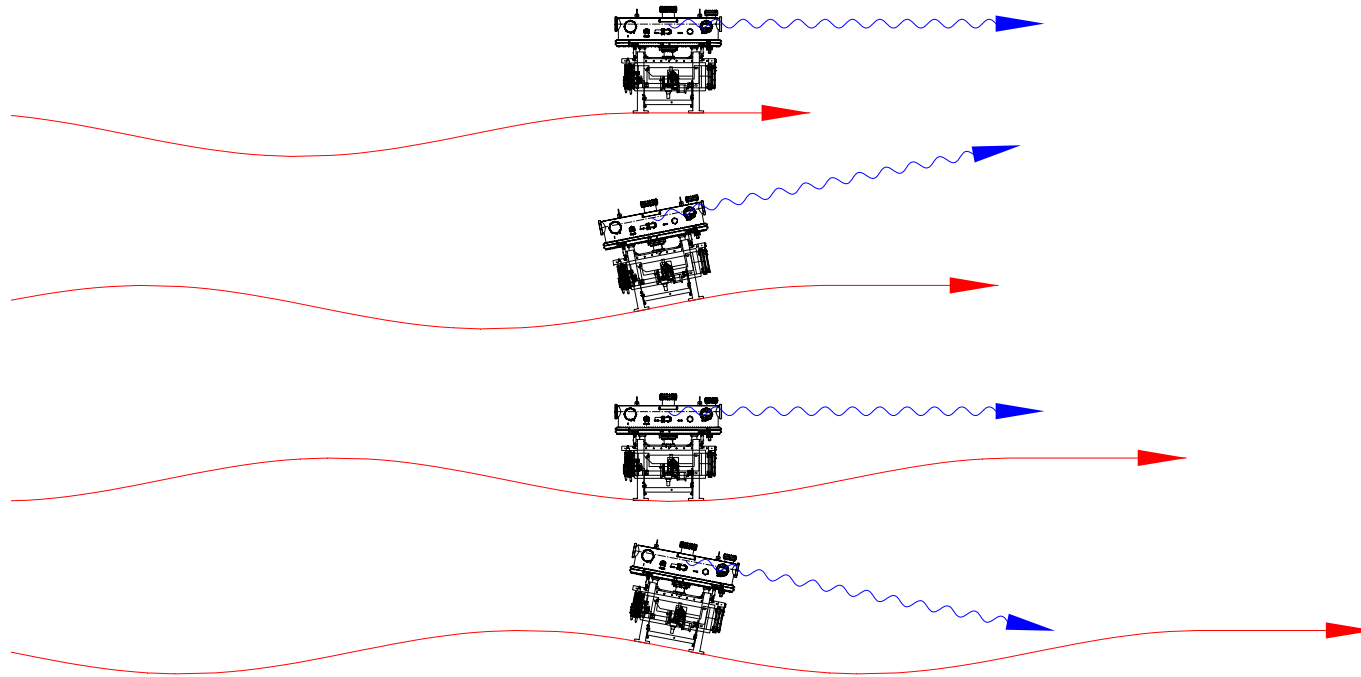

SC4-Photon Systems-XTOD Physics Requirements

Other important factors in the Offset Mirror Systems design:

Pointing Error/Stabilization:

Ground/floor vibrations and settling: an intrinsic limit

RMS Integrated Pointing Error < 1 nano-radian (our limit 100 nano-radians)

Ground Vibrations: "SLAC 2 AM Model"

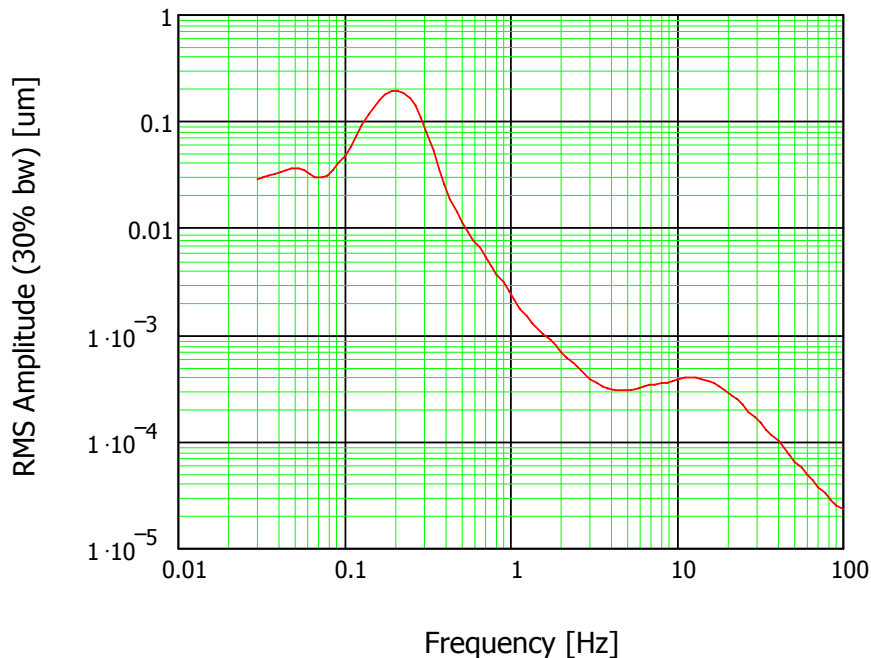

Pointing Error Spectrum, 1m Mirror Stand Base

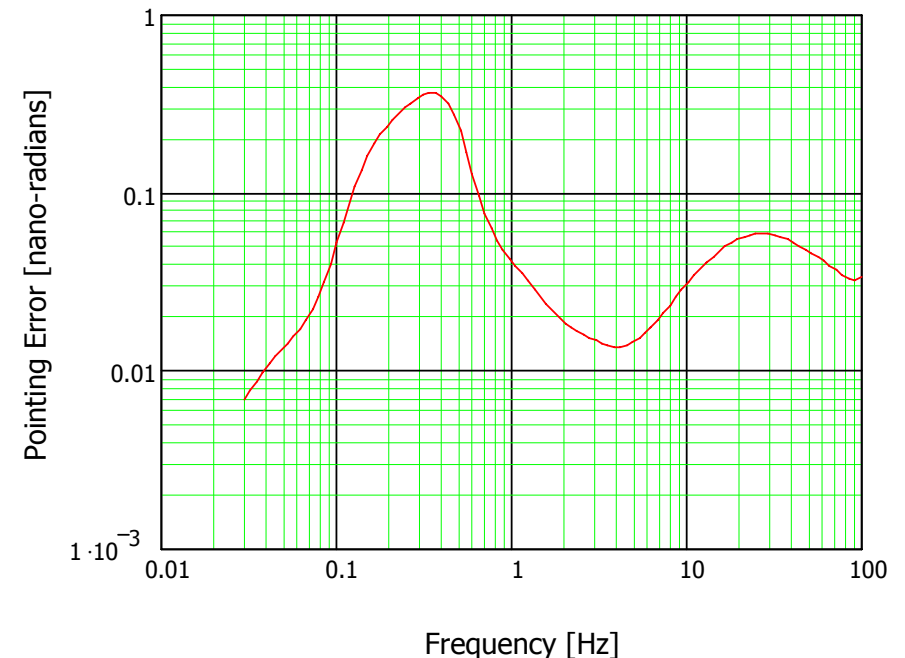

SC4-Photon Systems-XTOD Physics Requirements

Other important factors in the Offset Mirror Systems design:

HOMS tangential radius will require active control:
"Focusing" radius too large to be controlled statically.

The parameters, for 0.15 nm setting:

$$L_{\text{Rayleigh}} := 54.3\text{m}$$

$$L_{\text{eou_mir}} := 105.4 \cdot \text{m} \quad (\text{end-of-undulator to mid-point of downstream mirror})$$

$$L_{\text{eou_FEH6}} := 406.1 \cdot \text{m} \quad (\text{end-of-undulator to center of FEH Hutch 6})$$

Source-to-mirror distance:

$$F_1 := L_{\text{eou_mir}} + L_{\text{Rayleigh}} \quad F_1 = 159.7 \text{ m}$$

Mirror-to-experiment distance:

$$F_2 := L_{\text{eou_FEH6}} + L_{\text{Rayleigh}} - F_1 \quad F_2 = 300.7 \text{ m}$$

$$\theta := 1.44 \cdot \text{mrad} \quad (\text{mirror grazing angle-of-incidence})$$

To re-image the source at the experiment:

Mirror minor, saggittal radius:

$$R_1 := \frac{2 \cdot F_1 \cdot F_2}{F_1 + F_2} \sin(\theta) \quad R_1 = 300.4 \text{ mm}$$

Mirror major, tangential radius:

$$R_2 := \frac{R_1}{(\sin(\theta))^2} \quad R_2 = 144.9 \text{ km}$$

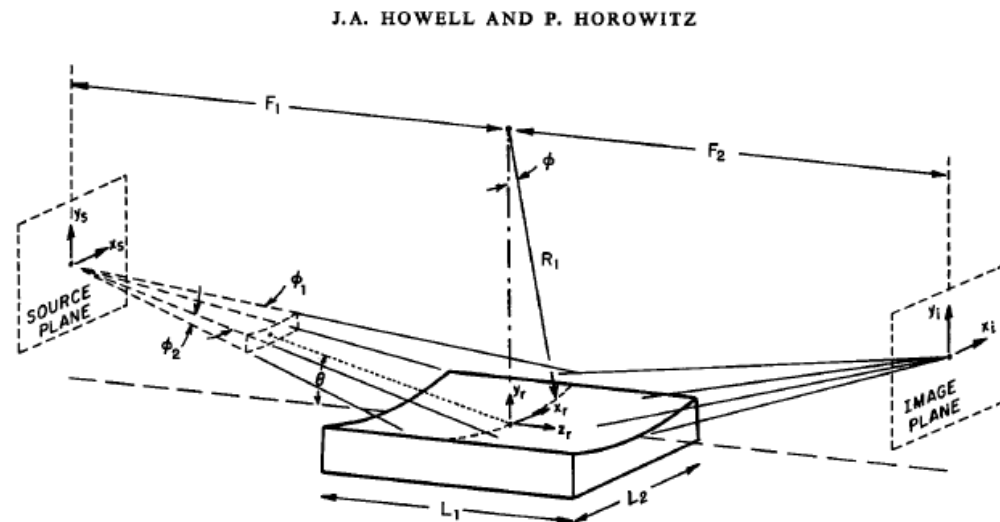

Fig. 1. X-ray condensing-mirror geometry.

SC4-Photon Systems-XTOD Physics Requirements

Other important factors in the Offset Mirror Systems design:

Is adequate time available/scheduled to procure the mirrors?

Historically, SSRL silicon mirrors in the 1 m length class have required 8 to 12 months to produce.

A very recent, informal conversation with a qualified mirror vendor suggested that our mirrors might be produced in substantially less time than this.

The present XTOD schedule could allow approximately 12 to 15 months between the completion of an optical element FDR and the installation of the mirror systems. This should allow adequate time for mirror procurement.

SC4-Photon Systems-XTOD Physics Requirements

Thank you!