



Tentative Agenda for the LUSI Diagnostics and Common Optics (DCO) Attenuator/Pulse Picker Preliminary Design Review

Date: December 3, 2008

Location: SLAC, Bldg 28 Large Conference Room

Review Committee	Agenda	Additional Documentation
Scott Debarger	9:00-9:45 <u>Physics Requirements</u> – David Fritz	<u>Reference Documentation</u>
Martin Nordby	9:45-10:30 <u>Attenuator Design</u> – M. Campell	<u>Drawings</u>
Andy Ringwall	10:30-10:45 Break	
Robert M. Duarte	10:45-11:15 <u>Pulse Picker Design</u> – R. Jackson	
	11:15-12:00 Questions & Report Writing	

Charge to the Committee

- Review and critique the Physics Requirements and Engineering Specifications documents for the Attenuator/Pulse Picker system
- Review the preliminary design of the Attenuator/Pulse Picker system.
 1. Does it meet the Physics Requirements
 2. Is the Engineering Specifications Document complete and ready for sign-off
 3. Is the design cost-effective
 4. Are design interfaces identified and communicated to the relevant parties
 - a. Controls and software interfaces
 - b. Safety review committees
 - c. Instrument design teams
 5. Is the component constructable and maintainable
 6. Is quality assurance adequately addressed at this stage of design
 7. Are the cost estimate & schedule reasonable

8. Is the component design ready to proceed to final design

[Stanford Linear Accelerator Center](#)

[Page Owner: LUSI Project Office](#)

[Page Editor: LCLS Web Master](#)



LUSI

Diagnostics and Common Optics

Attenuator and Pulse Picker PDR Physics Requirements

David Fritz – XPP Instrument Scientist
December 3, 2008

Outline

- Purpose of the Devices
- LCLS Provided Functionality
- LUSI Attenuators
 - Experimental Requirements
 - Material Choice
 - Expected Performance
- LUSI Pulse Picker
 - Experimental Requirements
 - Material Choice
 - Expected Performance

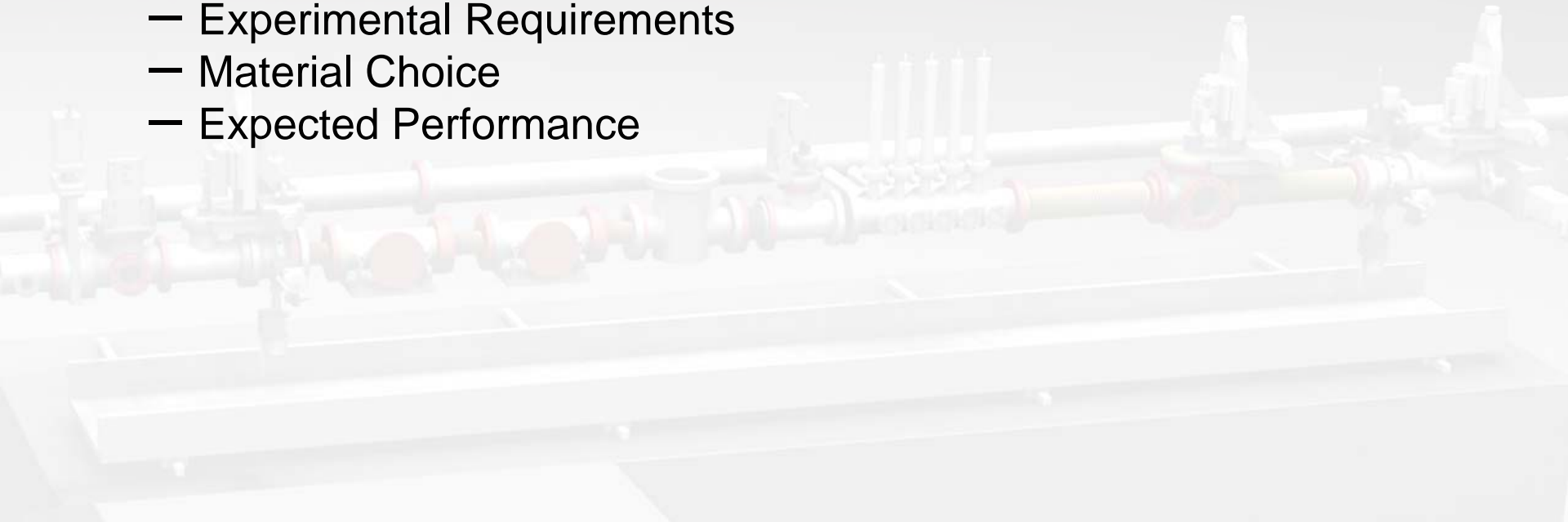

Purpose of the Device

- Attenuators
 - Control the intensity of X-rays incident upon the experimental sample or X-ray optics
 - Avoid beam induced sample damage
 - Avoid saturating X-ray detectors
 - Isolate the 3rd harmonic from fundamental
- Pulse Picker
 - Tailor the repetition rate of the X-ray pulse train
 - Up to 10 Hz
 - Down to an isolated pulse on demand

LCLS Provided Functionality

- Repetition rate control
 - LCLS Operators can control the rep. rate of the machine to some extent (10 – 120 Hz)
 - e⁻ beam feedback does not work well below 10 Hz
- FEE Attenuator System
 - Can be controlled by Users
 - Current design does not provide sufficient hard X-ray attenuation (see next slide)
- However, we are planning to multiplex the hard X-ray beam to various instruments. Thus this functionality must be individually provided per experiment.

FEE Attenuators

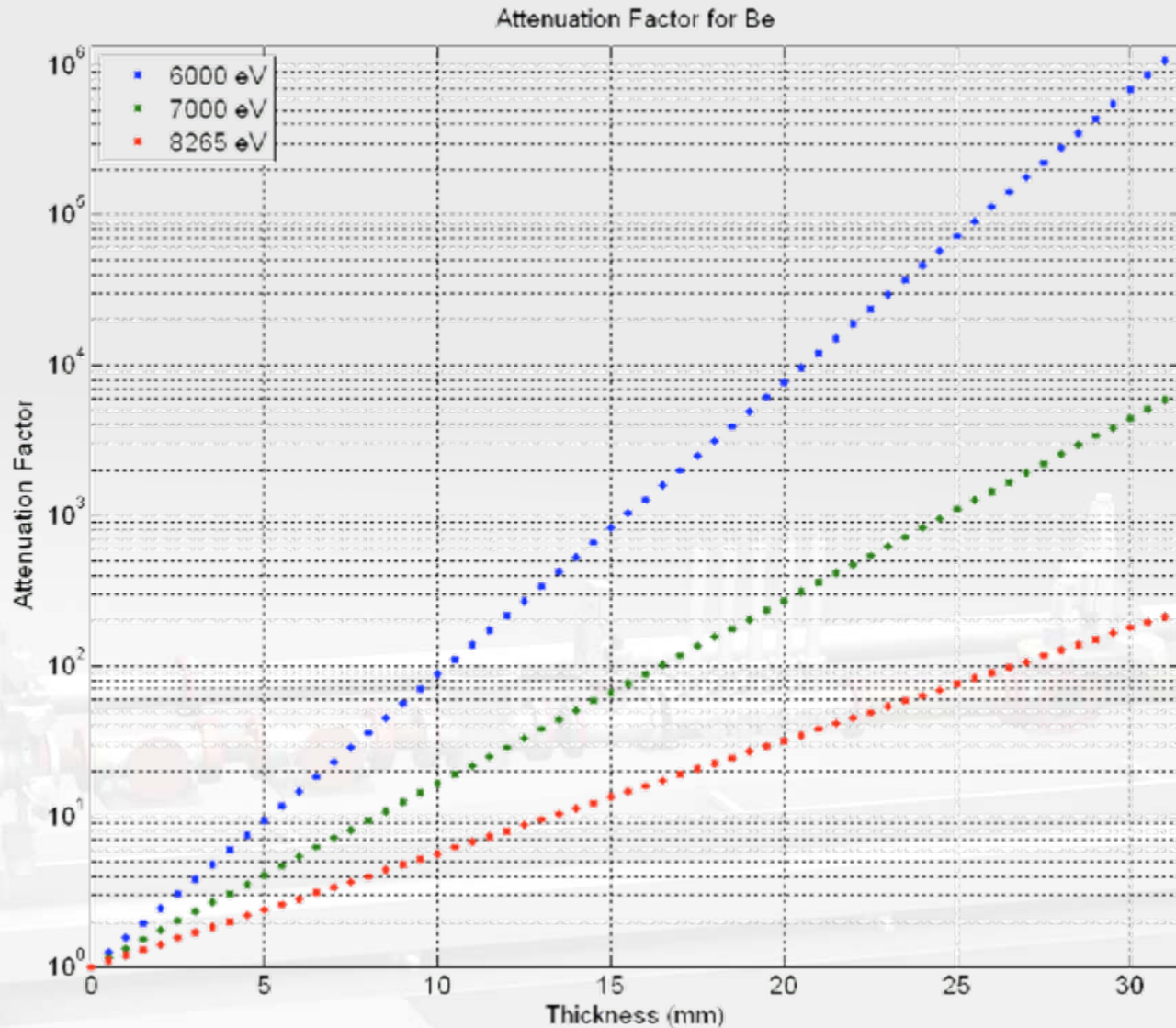

LUSI Attenuators Requirements

- Provide sufficient attenuation to view the direct beam on the Cornell and BNL detectors
 - 10^8 attenuation at 8.3 keV
 - 10^4 attenuation at 24.9 keV
- Withstand the full LCLS flux in NEH Hutch 3 (4-25 keV)
 - Use of the XTOD attenuators is permitted
- Filters won't put spatial structure on beam
- 1 cm clear aperture (min)
- Operate in Vacuum (10^{-7} Torr)
- State of the attenuator can be determined through visual inspection
- Positioning requirements
 - Will be discussed by Marc
- Controls requirements
 - Remote operation
 - Attenuator states recorded in experimental metadata

Material choice

- Silicon
 - Superior optical quality
 - Relatively high damage threshold
 - No absorption edges over photon energy range of interest
 - 1839 eV
 - Permits excellent isolation of 3rd harmonic

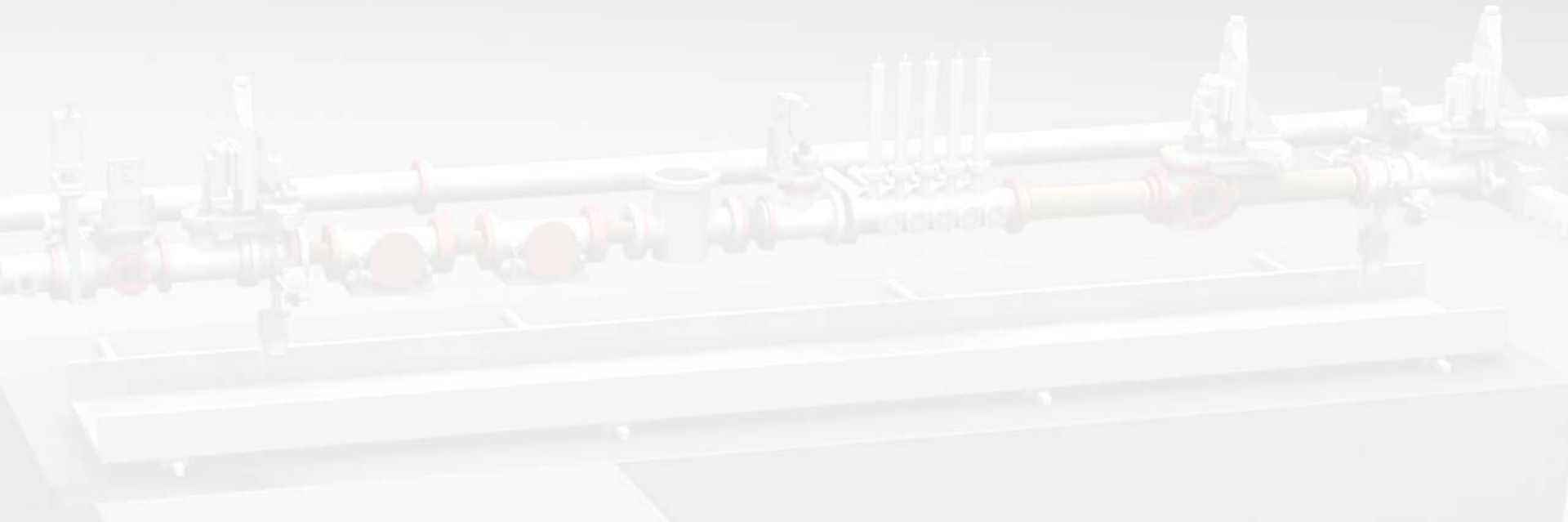

Silicon Damage

Hutch 2 dose for Si

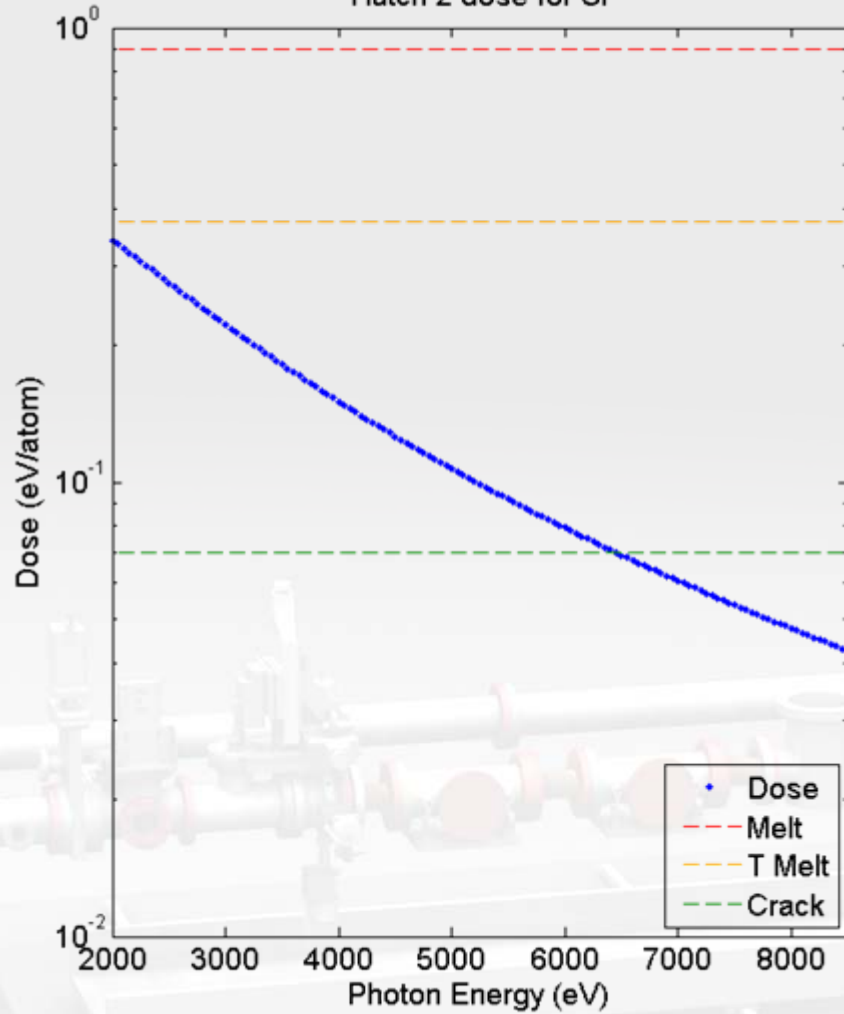

Hutch 4 dose for Si

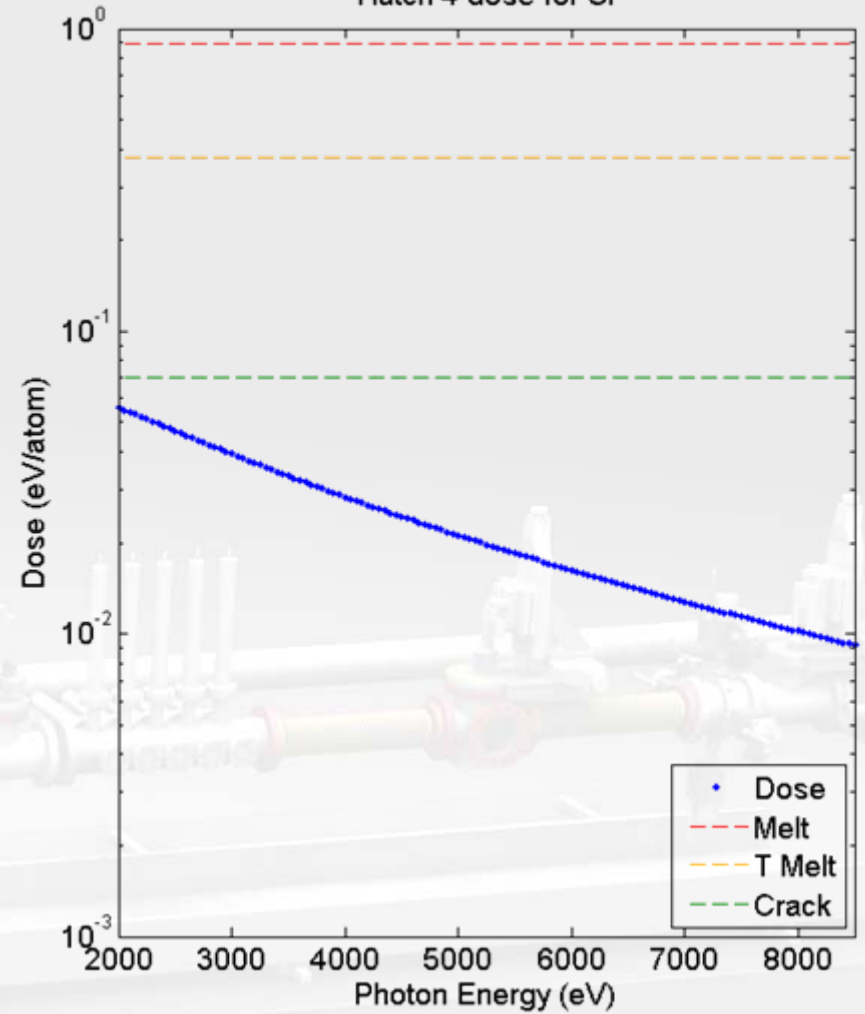

Silicon Damage

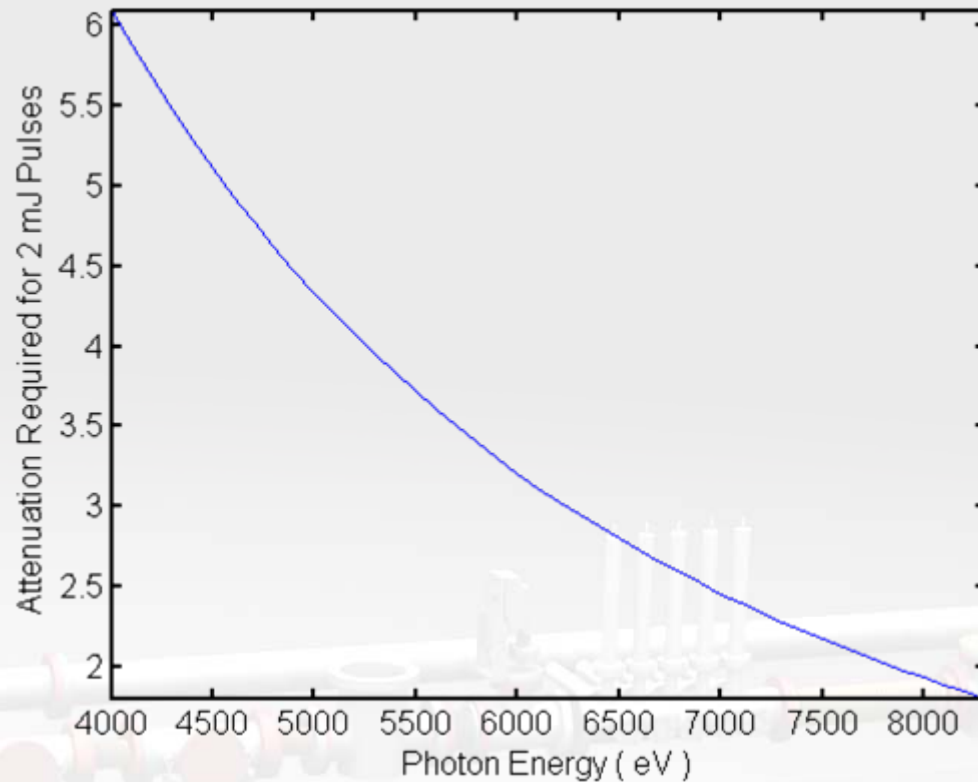

- Amount of attenuation required to be a factor of 3 below the fatigue threshold in NEH Hutch 3

Wavefront Distortion

50 nm rms roughness

10 nm rms roughness

1.4 nm rms roughness

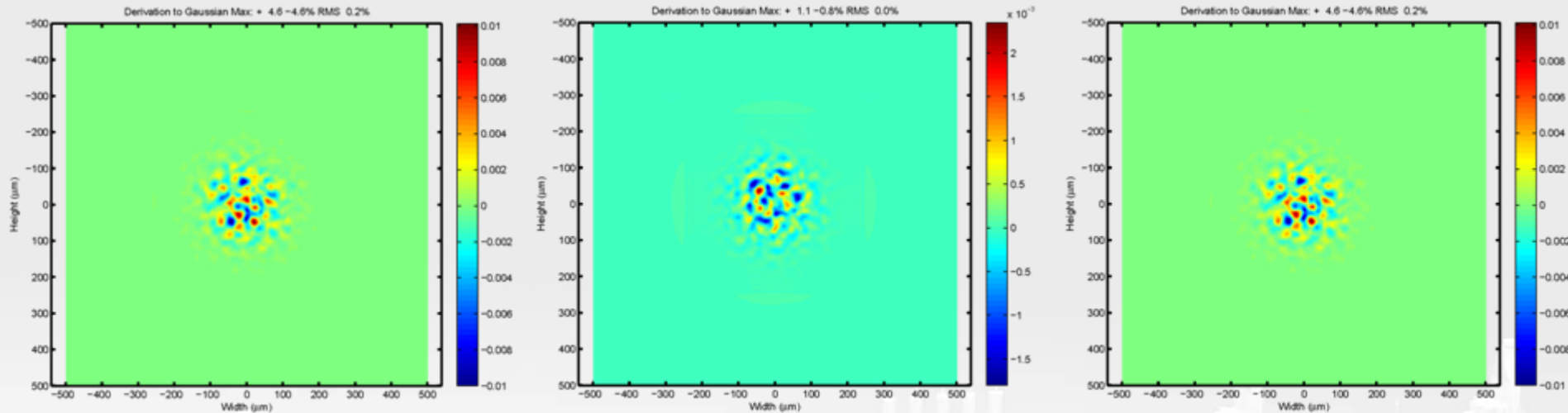

Wavefront calculations performed by M. Messerschmidt

- < 1% deviation from the incident wavefront is desirable
 - For 20 surfaces, ~ 3 nm rms roughness is needed

Filter Thickness Table

Attenuator Label	Thickness (μm)
Filter 1	20
Filter 2	40
Filter 3	80
Filter 4	160
Filter 5	320
Filter 6	640
Filter 7	1280
Filter 8	2560
Filter 9	5120
Filter 10	10240

- 10 filters are needed to have sufficient attenuation at high photon energies while also having a reasonable steps/decade at low energies

Performance Table

Photon Energy (eV)	Max Attenuation	Resolution	Steps per Decade
4000	$>10^{20}$	7.9867	1.108
4500	$>10^{20}$	4.4576	1.541
5000	$>10^{20}$	3.0349	2.074
5500	$>10^{20}$	2.3315	2.720
6000	$>10^{20}$	1.9344	3.490
6500	$>10^{20}$	1.6891	4.393
7000	$>10^{20}$	1.5268	5.441
7500	$>10^{20}$	1.4141	6.645
8000	$>10^{20}$	1.3327	8.017
8500	$>10^{20}$	1.2721	9.567
9000	$>10^{20}$	1.2258	11.308
9500	$>10^{20}$	1.1898	13.246
10000	$>10^{20}$	1.1613	15.397
10500	$>10^{20}$	1.1383	17.772
11000	$>10^{20}$	1.1196	20.380
11500	$>10^{20}$	1.1042	23.234
12000	$>10^{20}$	1.0913	26.344
12500	$>10^{20}$	1.0806	29.717
13000	$>10^{20}$	1.0714	33.374
13500	$>10^{20}$	1.0637	37.314
14000	$>10^{20}$	1.0570	41.552
14500	$>10^{20}$	1.0512	46.102
15000	$>10^{20}$	1.0462	50.972
15500	1.62×10^{18}	1.0418	56.177
16000	3.75×10^{16}	1.0380	61.722
16500	1.35×10^{15}	1.0346	67.617
17000	7.05×10^{13}	1.0317	73.872
17500	5.10×10^{12}	1.0290	80.501
18000	4.89×10^{11}	1.0267	87.516
18500	6.00×10^{10}	1.0246	94.912
19000	9.15×10^9	1.0227	102.697
19500	1.67×10^9	1.0210	110.907
20000	3.63×10^8	1.0195	119.512
20500	9.06×10^7	1.0181	128.563
21000	2.58×10^7	1.0168	138.030
21500	8.23×10^6	1.0157	147.928
22000	2.92×10^6	1.0147	158.242
22500	1.13×10^6	1.0137	169.025
23000	4.76×10^5	1.0129	180.192
23500	2.15×10^5	1.0121	191.835
24000	1.04×10^5	1.0114	203.929
24500	5.33×10^4	1.0107	216.419
25000	2.88×10^4	1.0101	229.377

$$\text{Steps per Decade} = \frac{1}{\log \text{ resolution}}$$

3rd Harmonic Isolation

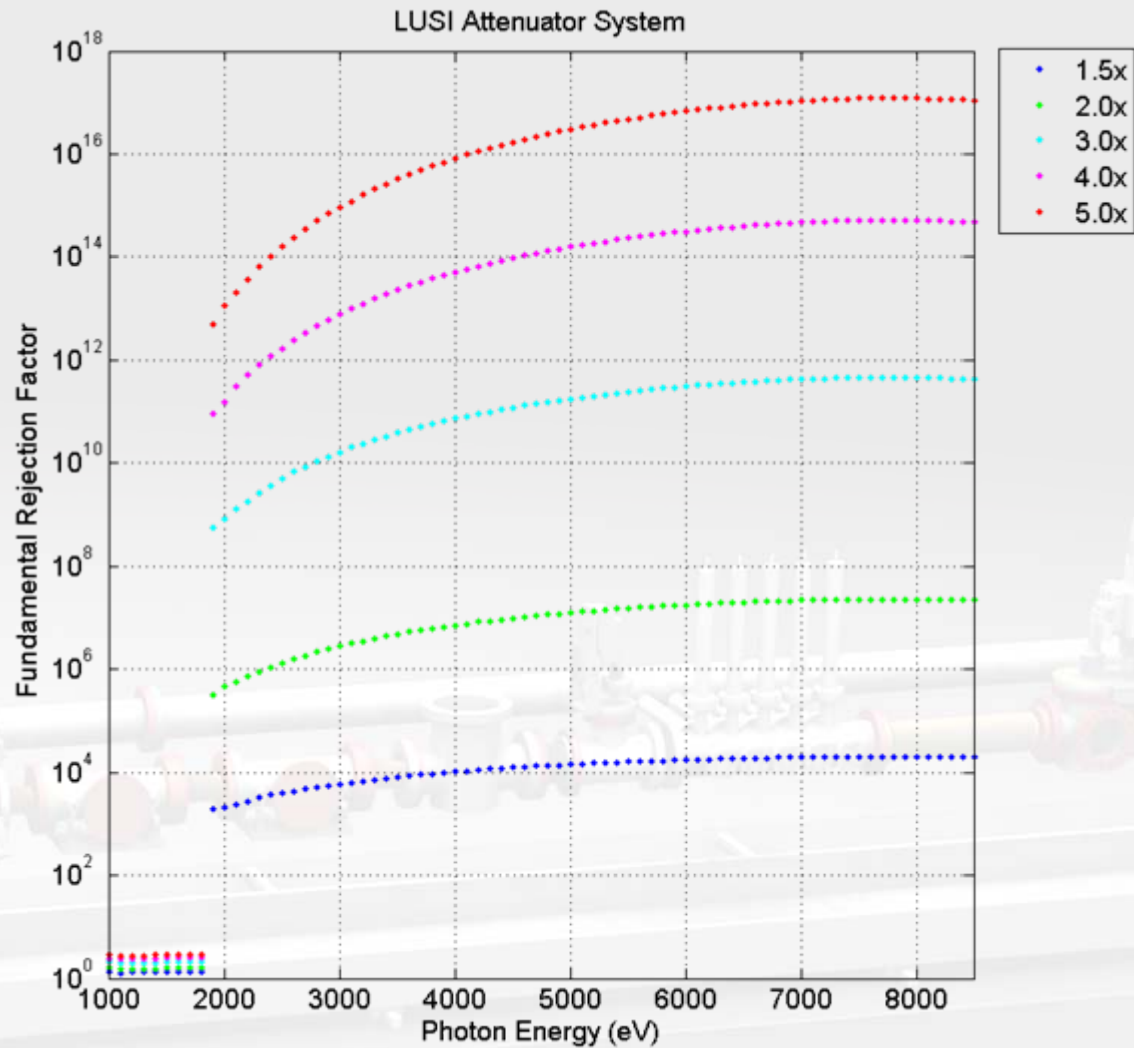

LUSI Pulse Picker Requirements

- Has ability to isolate a single pulse
 - Open and close cycle < 8 ms
- Operate at frequencies up to 10 Hz
- Transmission of X-ray beam shall be less than 10^{-11} across entire spectrum (2-25 keV)
- Withstand the full LCLS flux in NEH Hutch 2 (2-25 keV)
- 3.5 mm clear aperture when open
- Operate in Vacuum (10^{-7} Torr)
- State of the pulse picker can be determined through visual inspection
- Positioning requirements
 - Will be discussed by Rick
- Controls requirements
 - Remote operation
 - Pulse Picker state recorded in experimental metadata

Commerical Concept

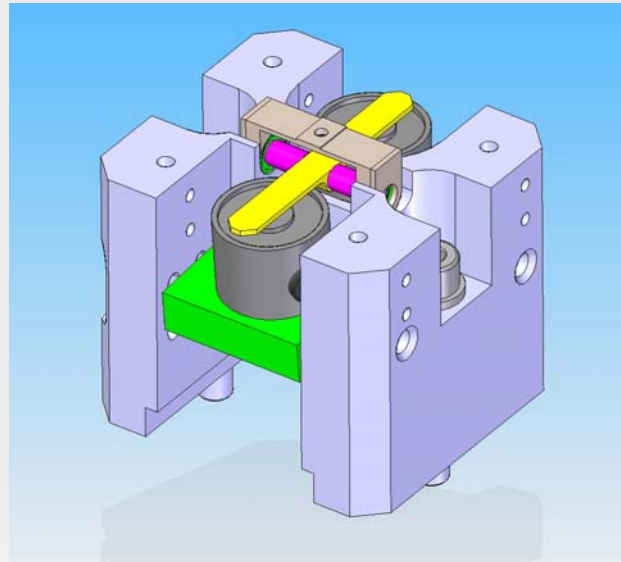

*<http://www.azsol.ch/>

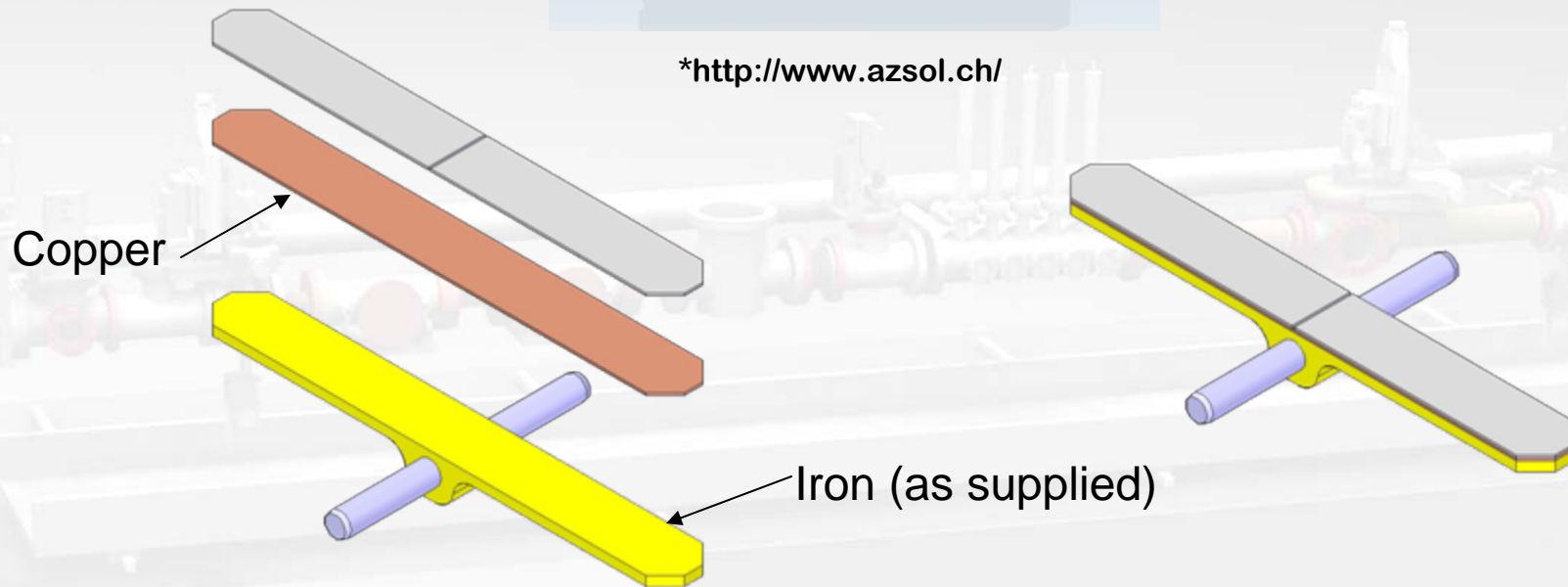

Pulse Picker Stopping Power

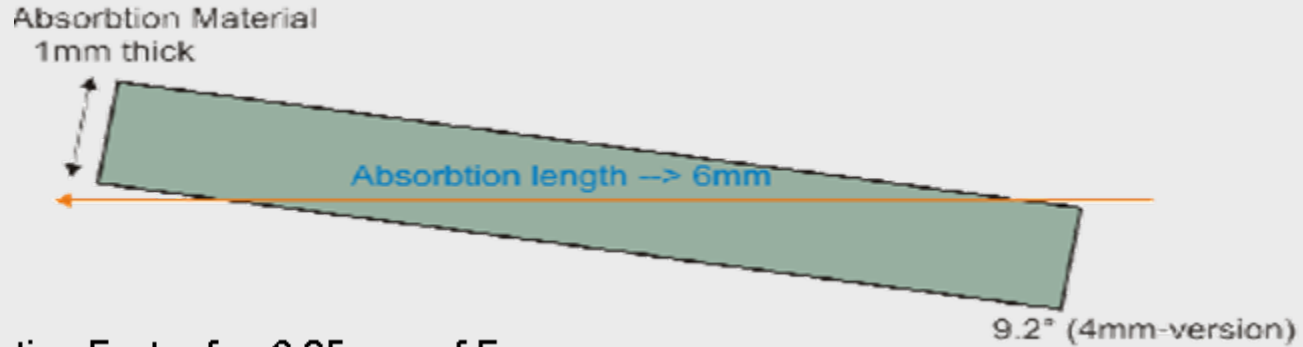

Attenuation Factor for 6.25 mm of Fe

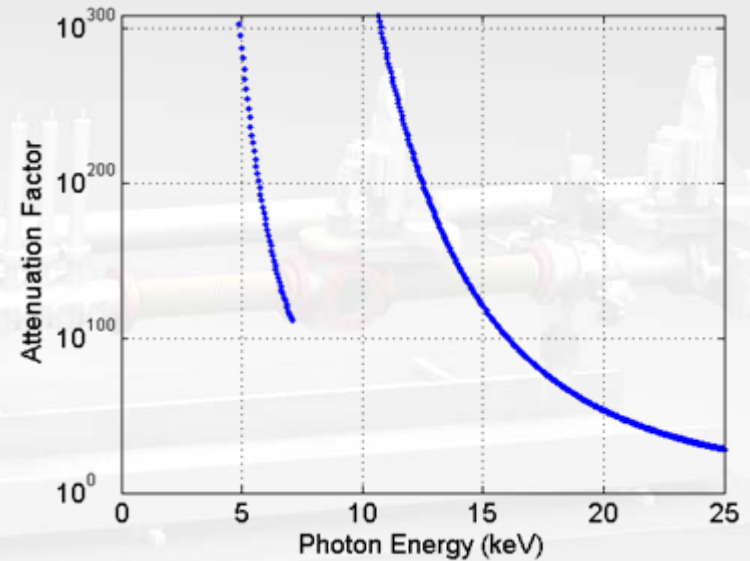
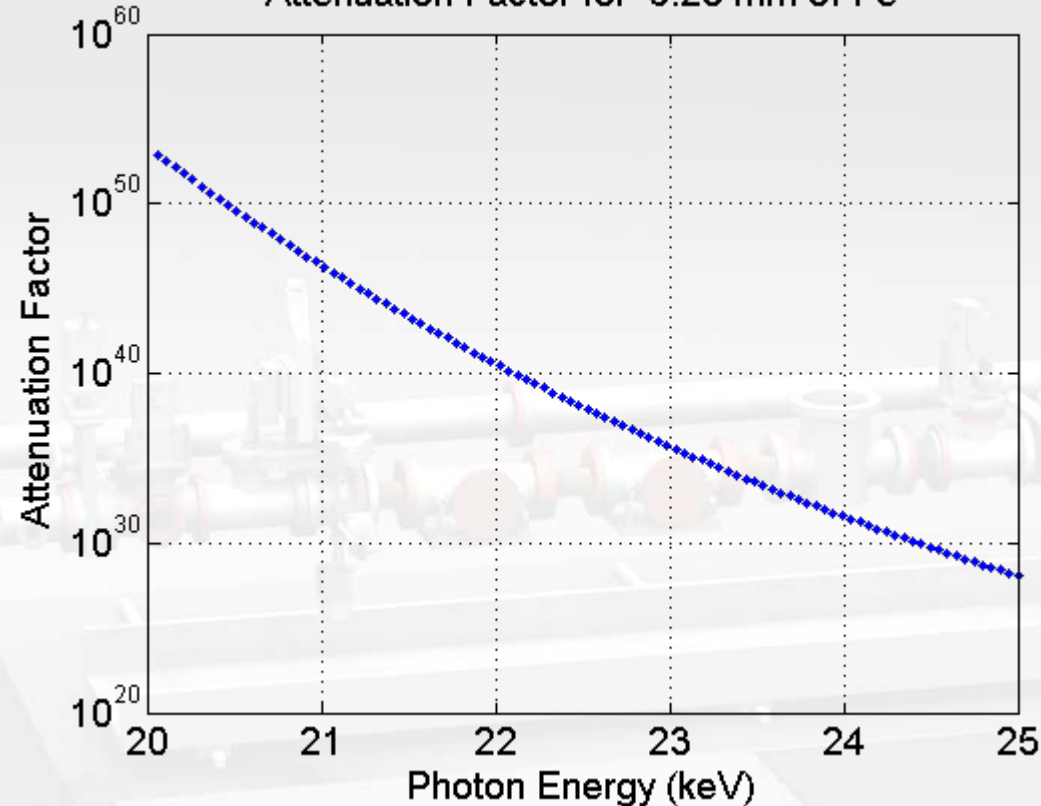

Pulse Picker Damage

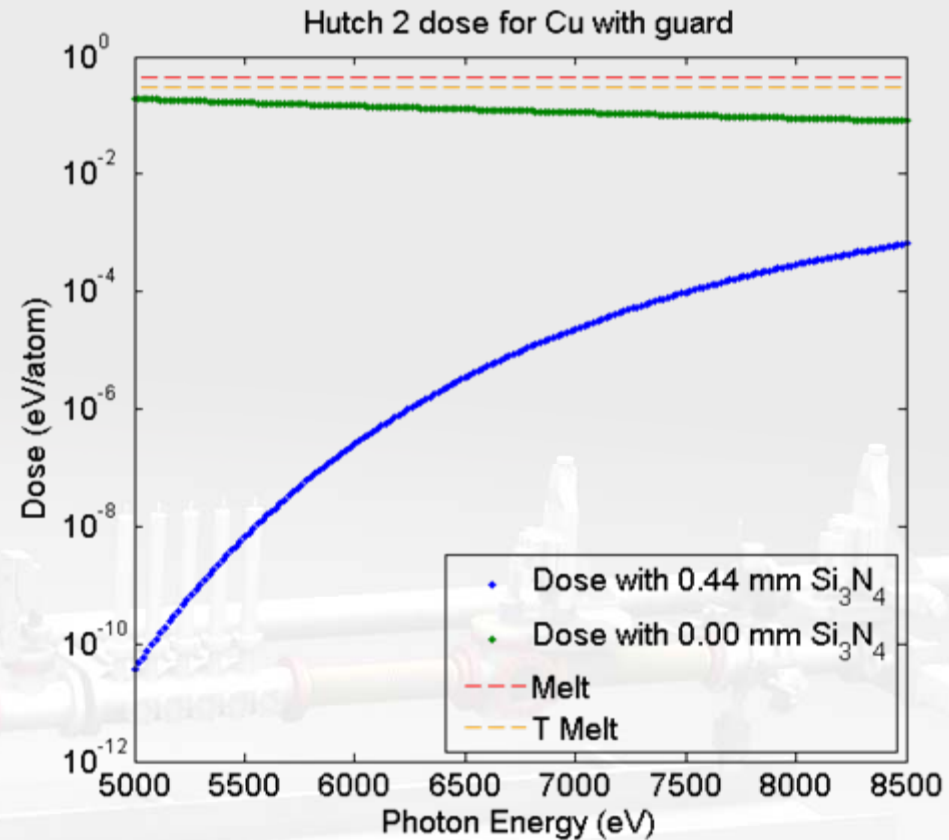
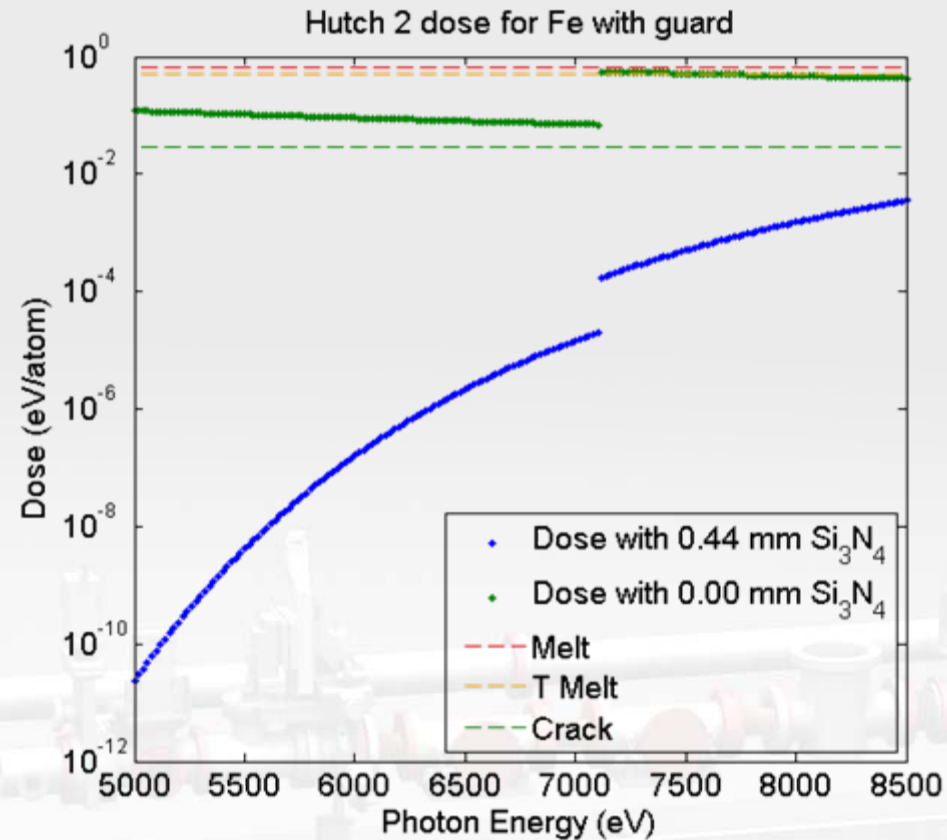

Attenuator & Pulse Picker Preliminary Design Review

Marc Campell

Rick Jackson

December 03, 2008

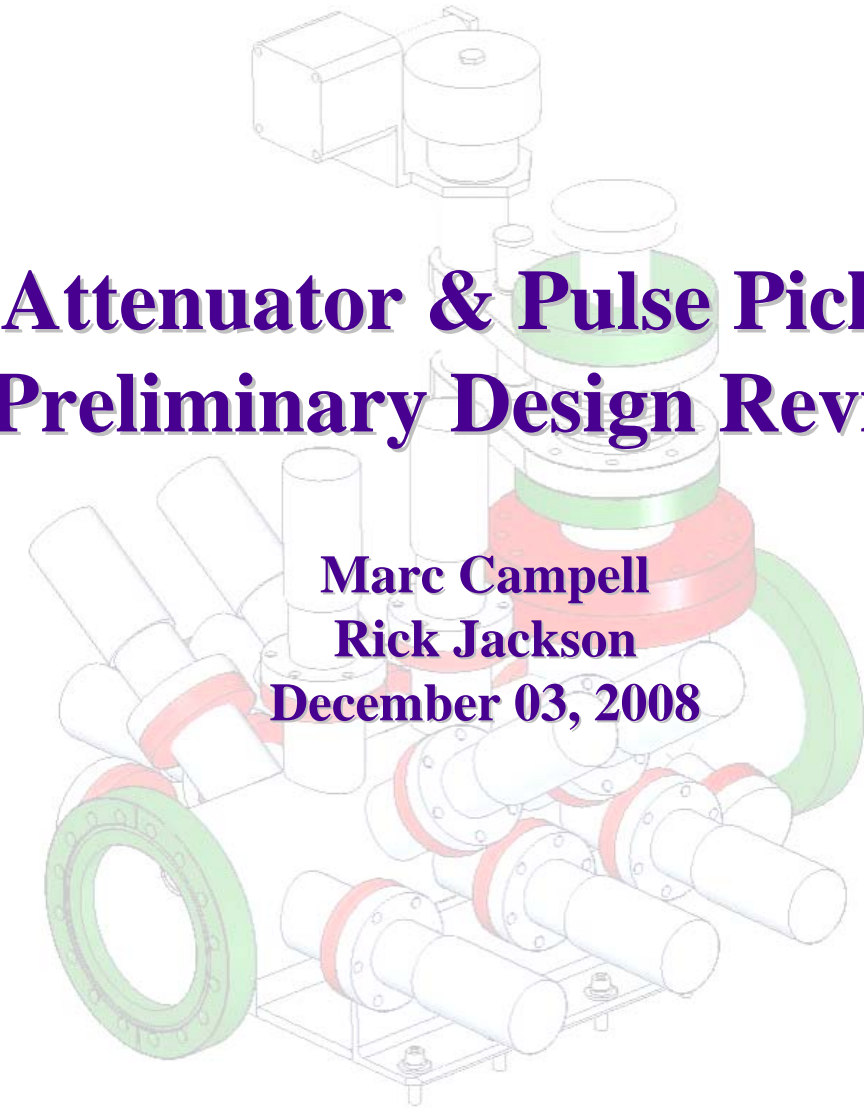

Agenda

- 9:00-9:15 Physics Requirements – D. Fritz
- 9:15-10:10 Attenuator Design – M. Campell
- 10:10-10:25 Break
- 10:25-11:15 Pulse Picker Design – R. Jackson
- 11:15-12:00 Questions & Report Writing

Goal of PDR

- Approval of the Attenuator and Pulse Picker:
 - ✓ Physics Requirements Document (PRD) and
 - Engineering Specification Document (ESD) and
 - Preliminary designs
- Approval to complete final design
- Approval to fabricate test articles and
- Approval to place long duration procurements
 - Shutter Assembly for Pulse Picker after completion of Engr. Test
- NOTE: The 6 degree of freedom support that is used on all DCO devices will be covered in a future review.

Definitions

- Attenuator includes chamber, 6 degree of freedom mount, filters, actuators and viewing system.
 - Marc
- Pulse Picker includes Shutter Assembly, positioning system and viewing system.
 - Rick

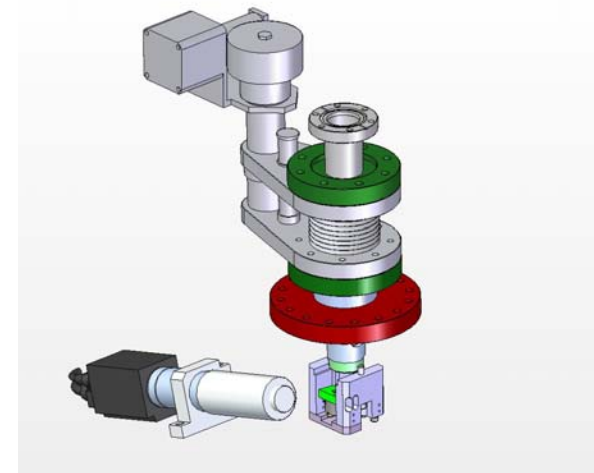
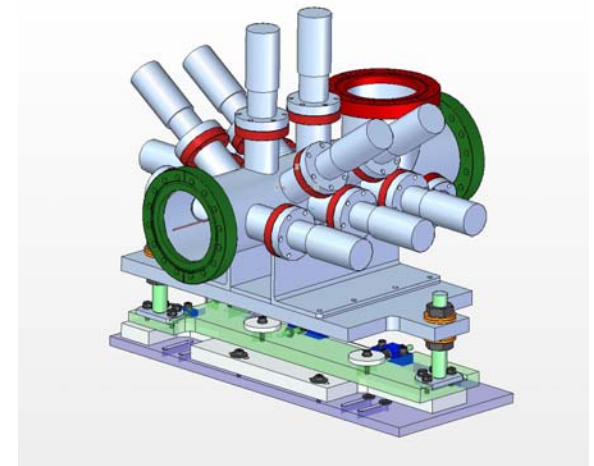

Attenuator-Pulse Picker PDR

Attenuator PDR

Outline

- History
- Attenuator – Pulse Picker Key Features
- Attenuator
 - Science/technical objectives, requirements
 - Preliminary design & engineering analyses
 - Design interfaces
 - Control/software requirements
 - Quality control, reliability
 - Safety
 - Cost & schedule
 - Summary
 - Action Items

History

- Concerns about overall Z length for XPP – Summer '08
- Repeating combinations of DCO devices identified for all Instrument lines
- Investigation of combining devices into single chamber to reduce length – September '08
- Combining and refining Attenuator & Pulse Picker reduced Z length 10.87 inches
- Decision to proceed with common chamber approach – October '08
- Attenuator design tasks pulled up ~5 months to support Pulse Picker first use on 3/18/10 (XPP)

Attenuator-Pulse Picker in XPP

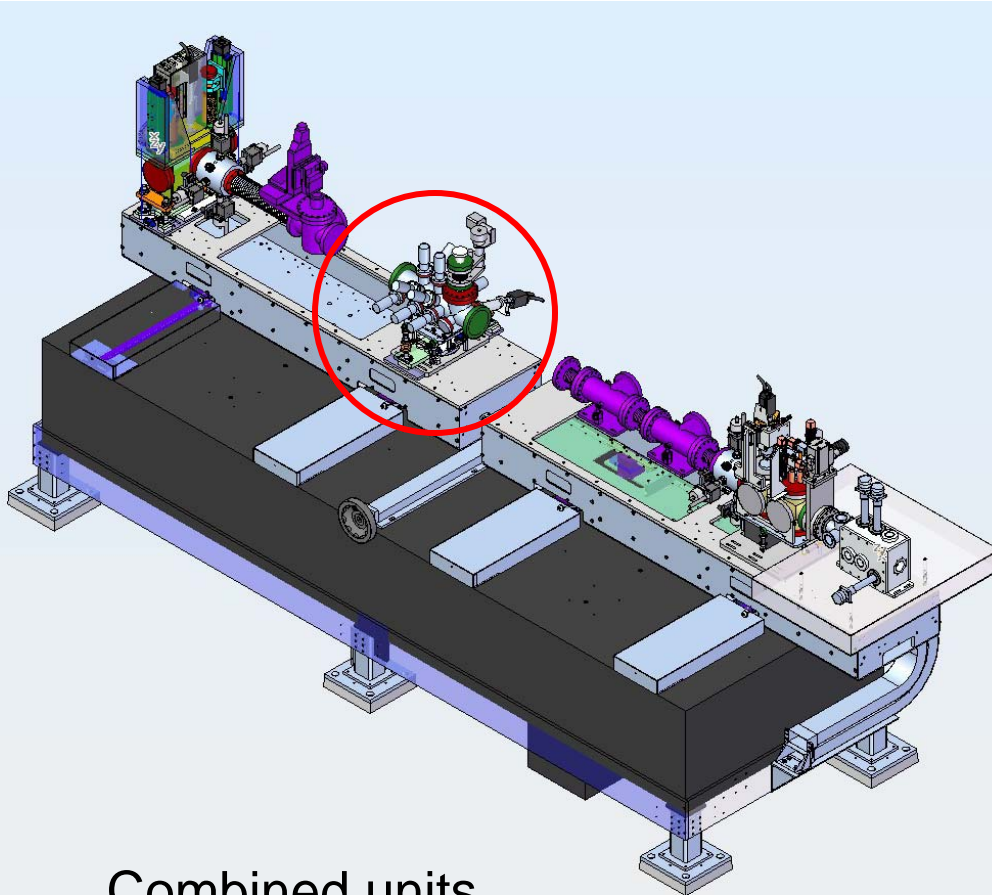

Combined units

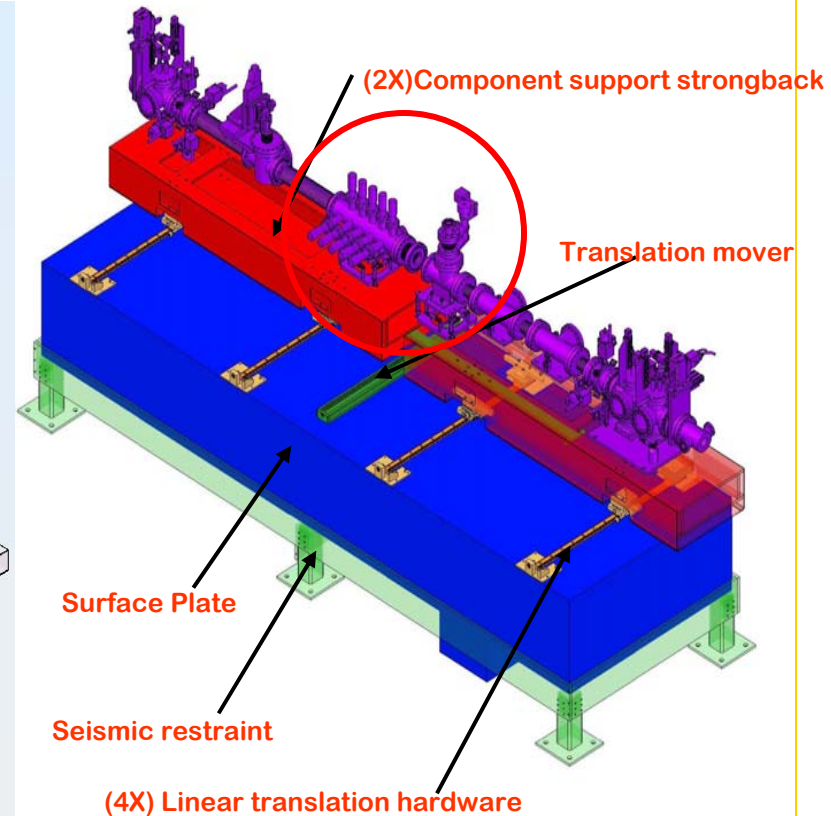

Separate units

Attenuator-Pulse Picker PDR

Attenuator – Pulse Picker Key Features

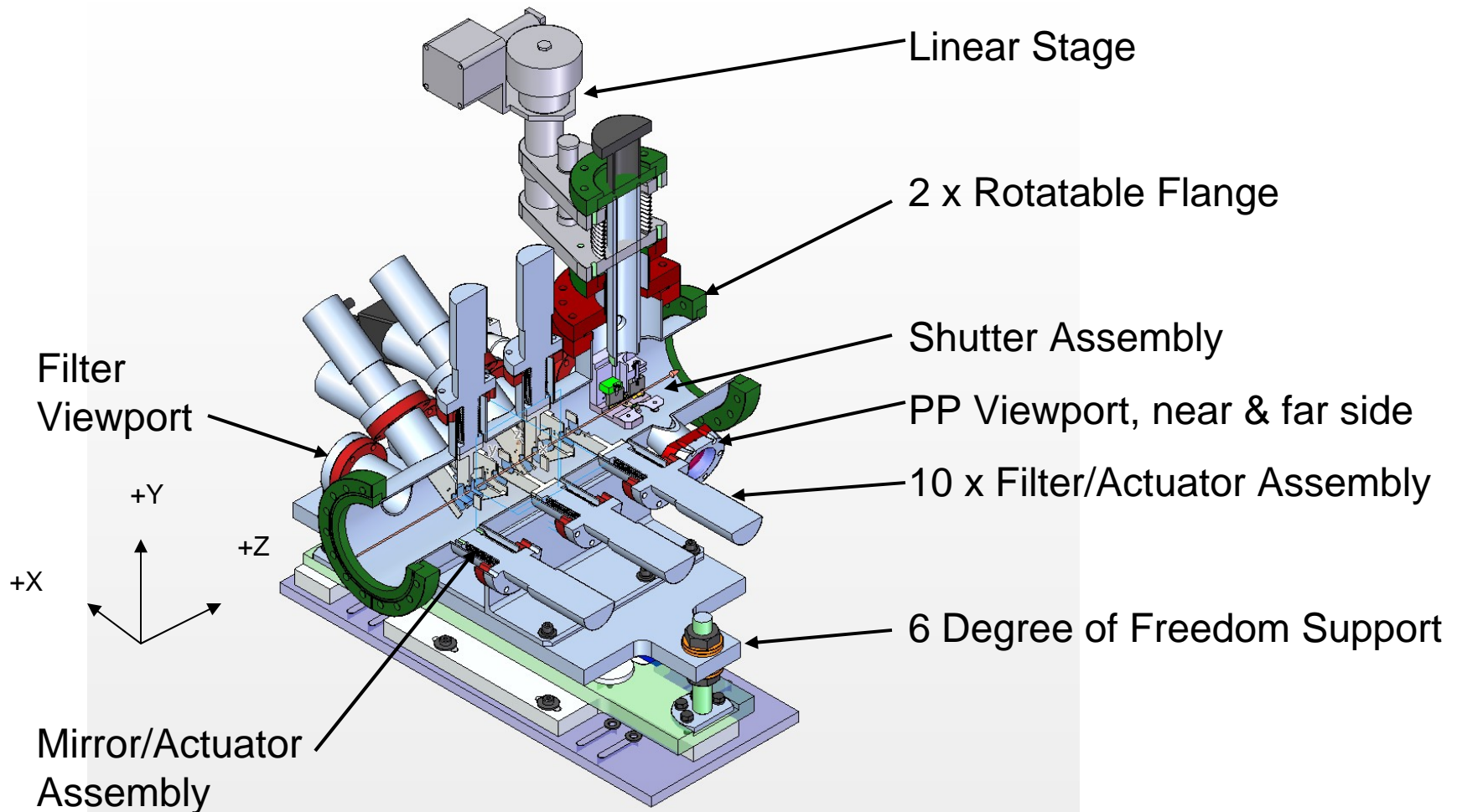

Attenuator-Pulse Picker PDR

A-PP Envelope

- Approximate weight = 140 lbs

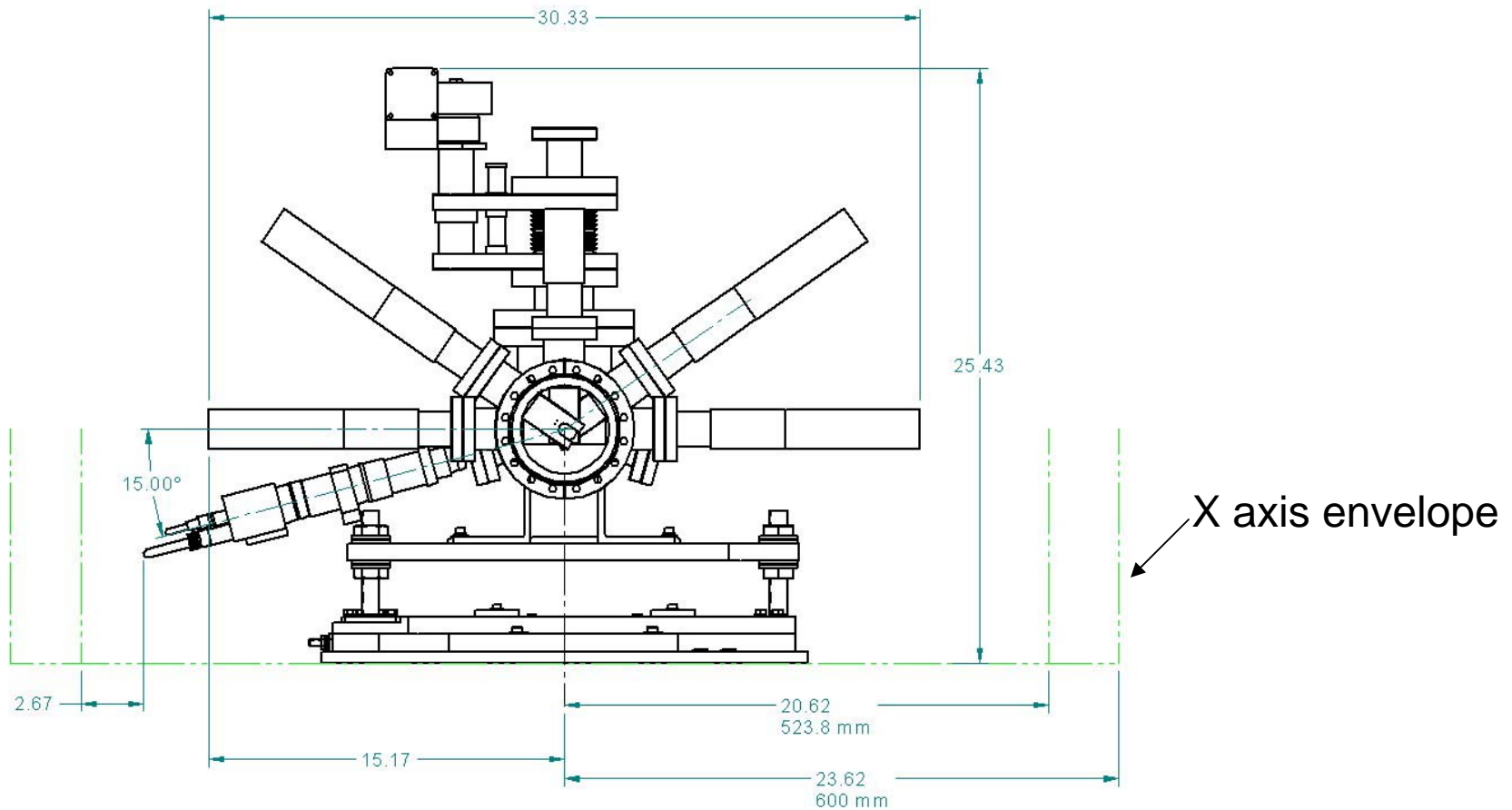

Attenuator-Pulse Picker PDR

Science Objectives/Requirements

- The Attenuator Device controls the X-ray intensity incident upon the sample by placing silicon filters in series into the beam line.
- The Attenuator Device shall attenuate 25 keV photons by a factor of 10^4 .
- The Attenuator Device shall attenuate 8.3 keV photons by a factor greater than 10^8 .
- The Attenuator Device shall provide incremental attenuation of at least 3 steps per decade for all energies greater than 5,700 keV.

Key Features

- Reversible Chamber orientation
 - Rotatable flanges at both ends
 - PP can be installed in 2 orientations on its flange
- Due to limited access on -X side
 - Filter inspection viewport and mirror actuator are swappable
 - PP viewport/camera can be installed on either side
- Filter actuator ports are spiraled around vessel to minimize port spacing and overall Z length

Key Features (cont)

- Sum of all filter thicknesses, 20,460 μm , must attenuate 25keV photons by 10^4
 - Each filter doubles in thickness
 - 10 filters provide 1024 combinations from 0 to 20,460 in 20 μm steps
- Silicon selected for filters
 - Damage threshold in FEL beam
 - High purity, ultra-polished wafers in required thicknesses are commercially available at reasonable costs
- Thickest filter are up-beam to protect thinner ones
 - Any Filter/actuator assembly can go into any port

Attenuator Main Components

- Chamber Assembly
- Actuator/Filter Assembly
- Filter Holder Assembly
- Filter
- Actuator/Mirror Assembly (Filter inspection)
- 6 Degree of Freedom support

Drawing Tree

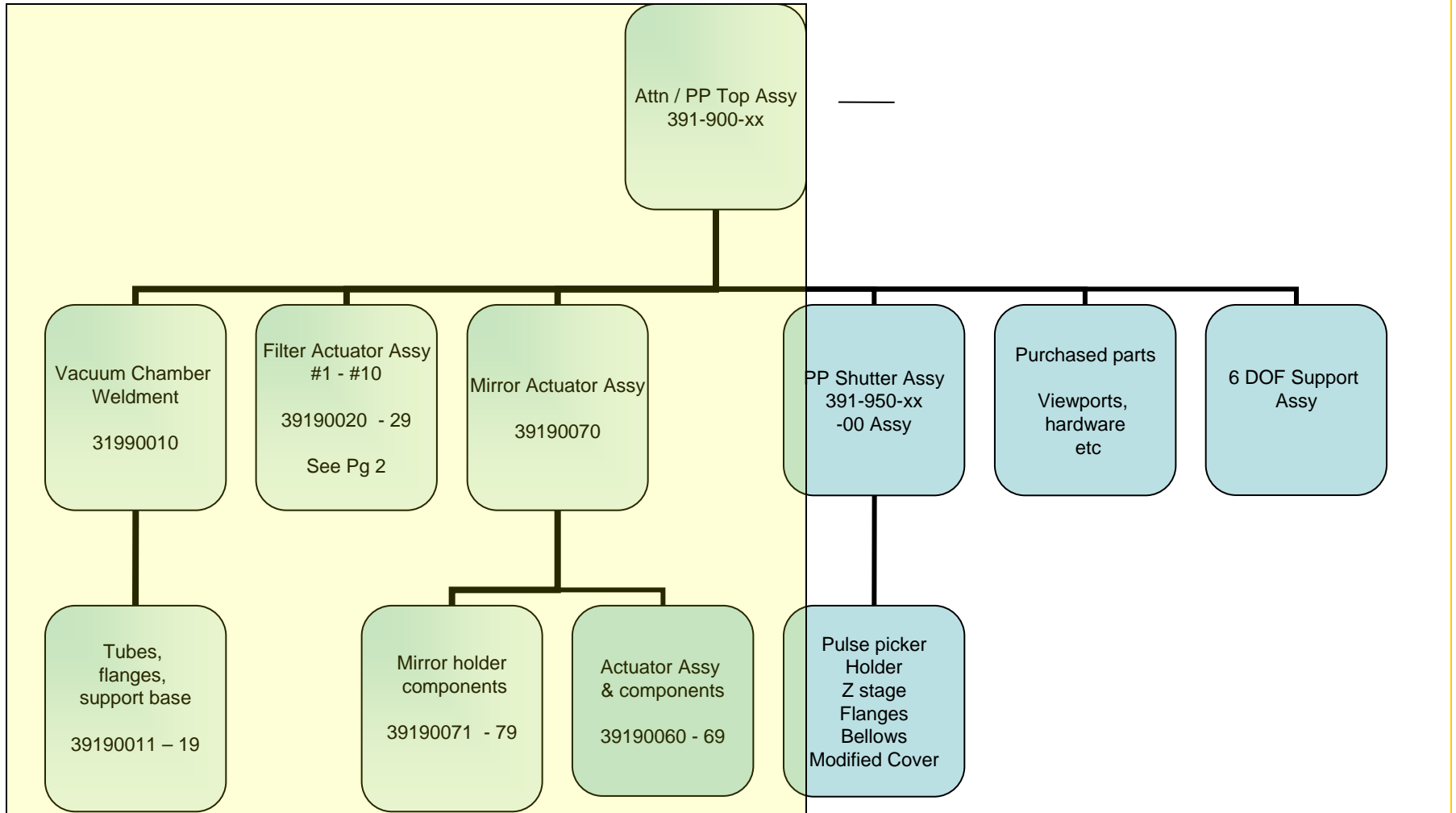

Attenuator-Pulse Picker PDR

Drawing Tree (cont)

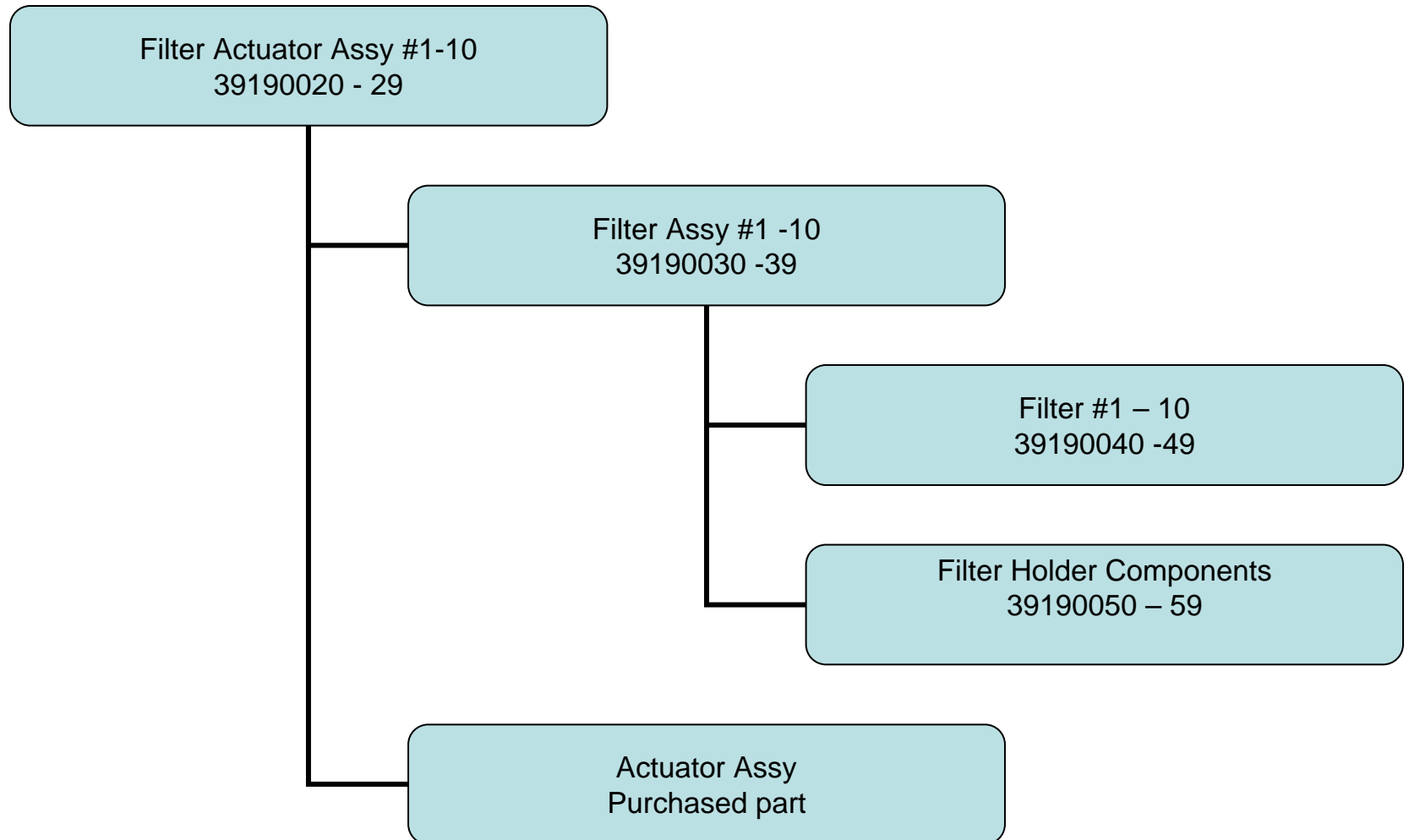

Attenuator-Pulse Picker PDR

Chamber Assembly

4" dia. Chamber

6" non-rotatable CF flange

2 x 6" rotatable CF flange

12 x 2.75" non-rotatable CF flange

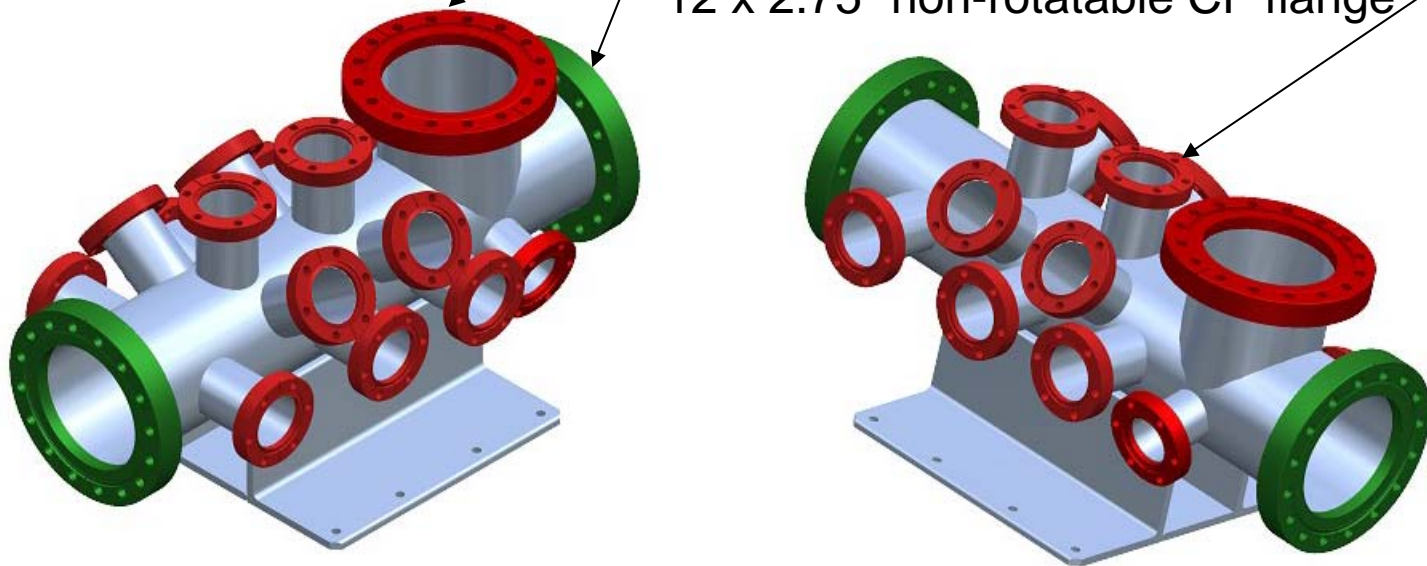

Attenuator-Pulse Picker PDR

Chamber Assembly

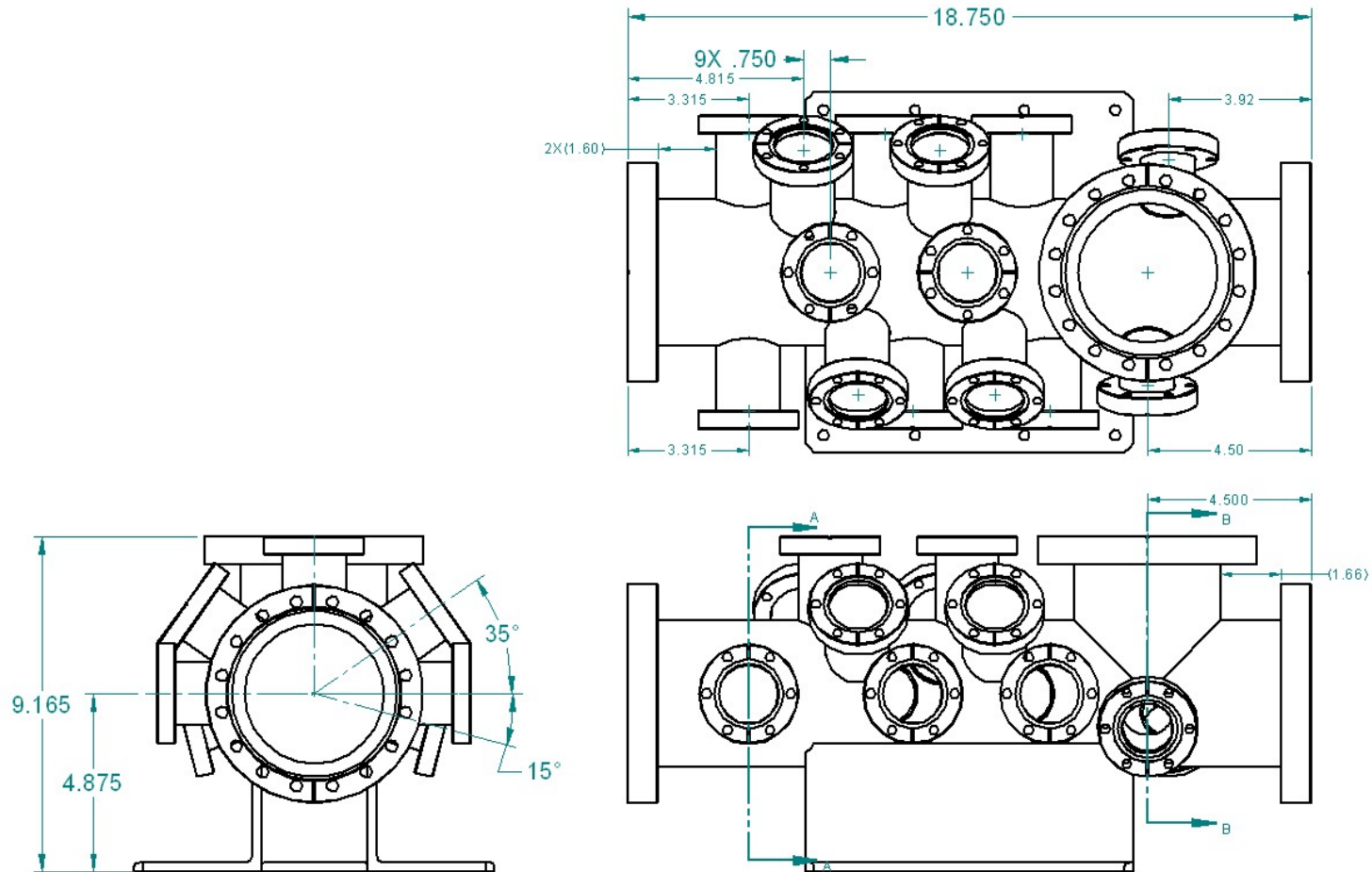

Attenuator-Pulse Picker PDR

Chamber Assembly (cont)

- .75" spacing between port centers

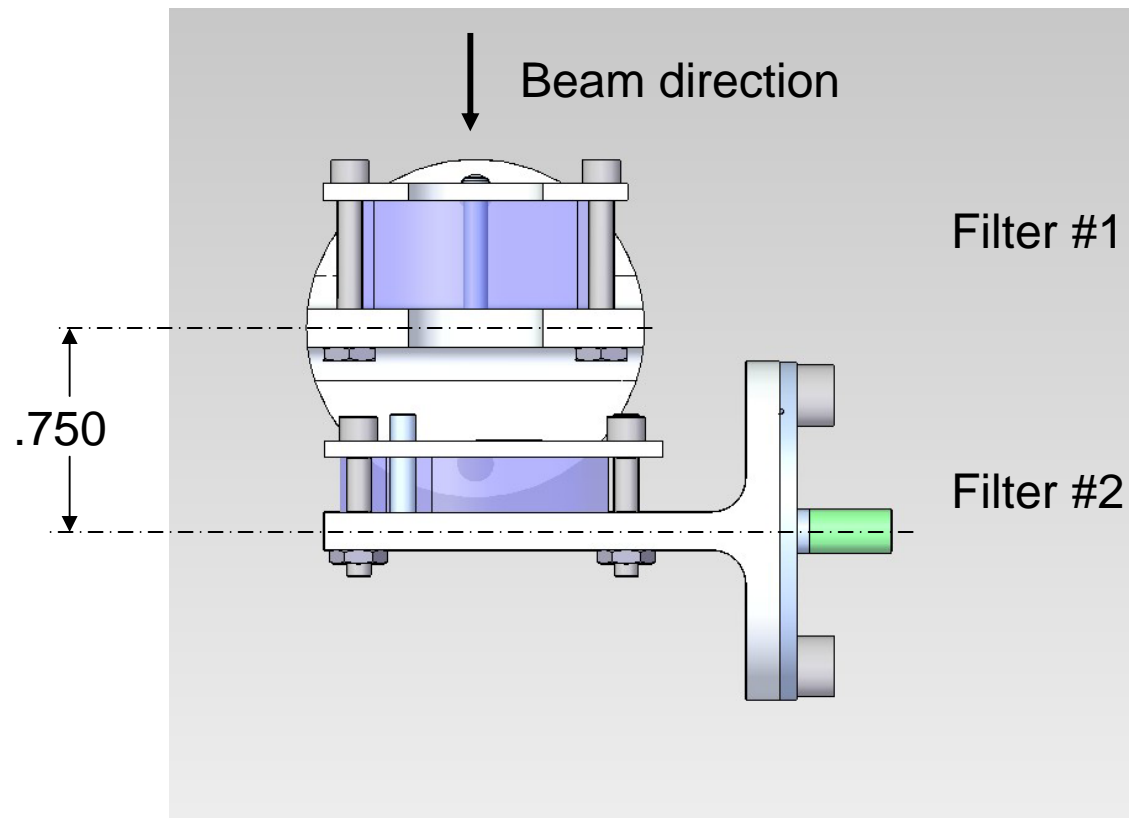

Attenuator-Pulse Picker PDR

Actuator/Filter Assy Design

- Actuator is a modified VG Scienta P/N ZLDS925W
 - 2.75" diameter flange vs 1.33" diameter standard
 - Shorter shaft being investigated to improve stiffness and reduce X axis footprint
- Stepper motor drive
- Can be unbolted from chamber for servicing
- Filter holder threads into shaft, oriented with jam nut

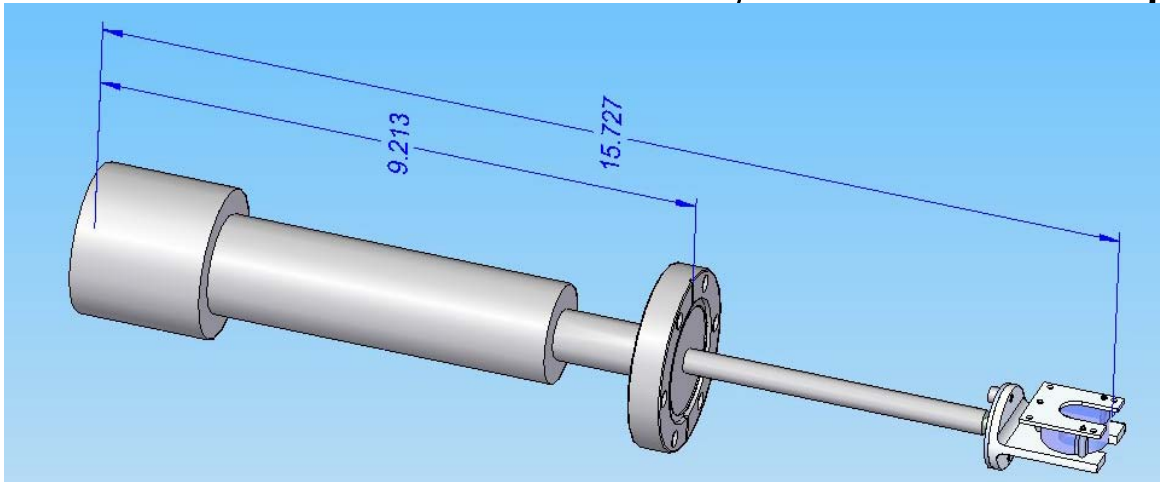

Attenuator-Pulse Picker PDR

Filter Holder Assembly

3 Registration Pins

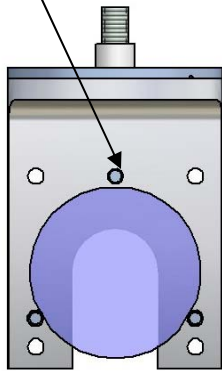

Cover removed

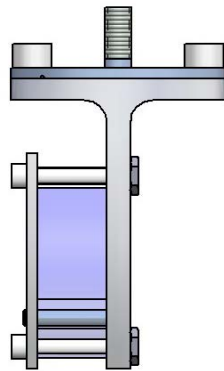

Thick Filter

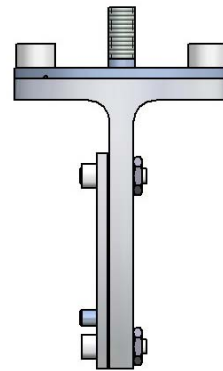

Thin Filter

Vent path

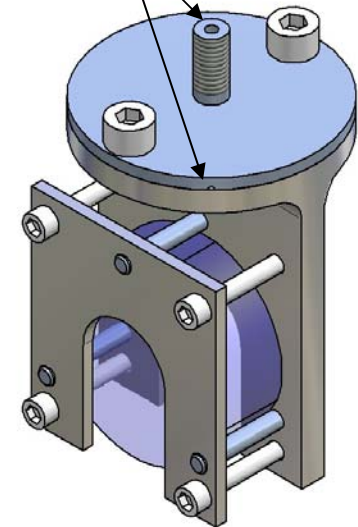

Filter Holder

- Single design adaptable to all filter thicknesses
- Horseshoe design allows filter movement while beam is on.
- Pins register filter in place.
- 2 piece design allows for pitch adjustment if required
- Cover provides light clamping force for thicknesses down to 640 μ m.
 - May use preload indicating feature such as wave washer
- Thinner filters are retained but not clamped using spacers between the cover & base to prevent breakage.
 - It is expected that these will be held in place by electrostatic forces.

Filter Holder (cont)

- Other design options considered
 - Filter bonded directly to holder
 - Filter bonded to carrier which then clamped to holder
- Bonding option dropped
 - possible long term effects of radiation on adhesive strength (not verified).
 - Bonding fixtures required
 - Filter replacement more difficult

Filter Design

- 1.0" Dia. silicon crystal wafer
 - 10 thicknesses as shown below
 - 3 flats for registration
 - $\langle 100 \rangle$ crystal orientation
 - Double sided polish
 - Surface roughness $< 5\text{\AA}$ or $< 20\text{\AA}$ for filters below $100\mu\text{m}$ thick

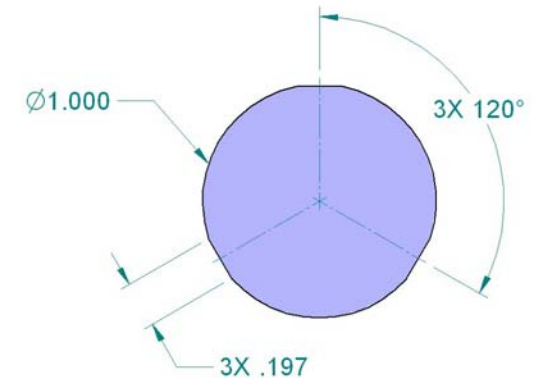

10,240µm	5,120	2,560	1,280	640
.403"	.202"	.101"	.050"	.025"
320µm	160	80	40	20
.013"	.006"	.003"	.0015"	.0008"

Attenuator-Pulse Picker PDR

Mirror Actuator Assembly

- Mirror inserted into chamber to inspect individual filters
- Camera provides magnification
- Mirror holder 2 piece construction is adjustable

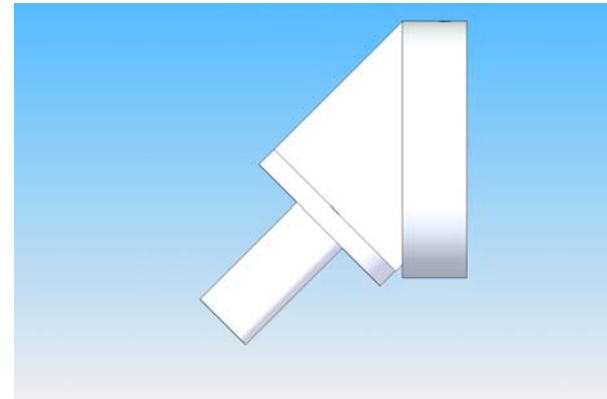
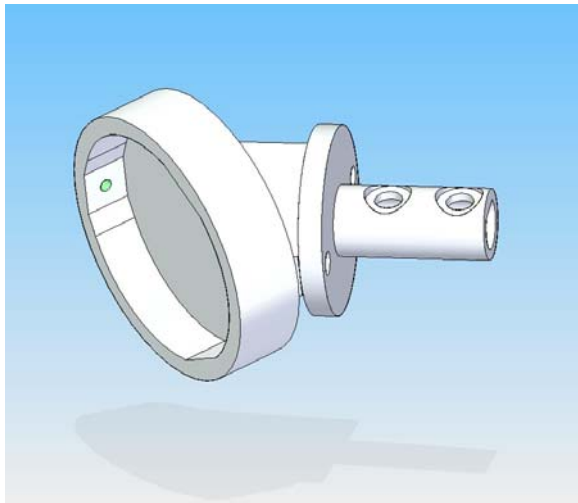
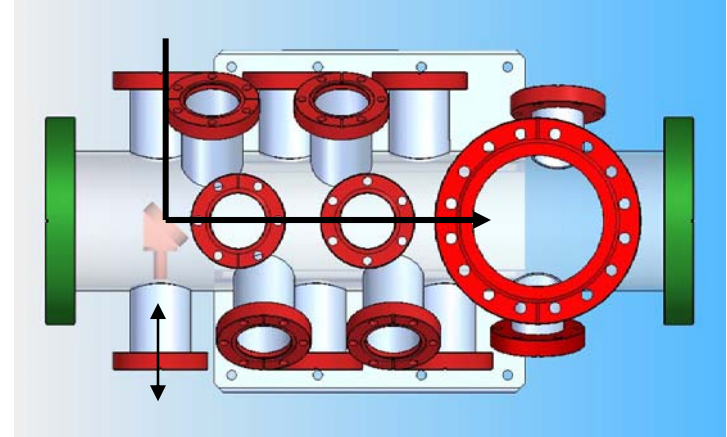

6 Degree of Freedom Support

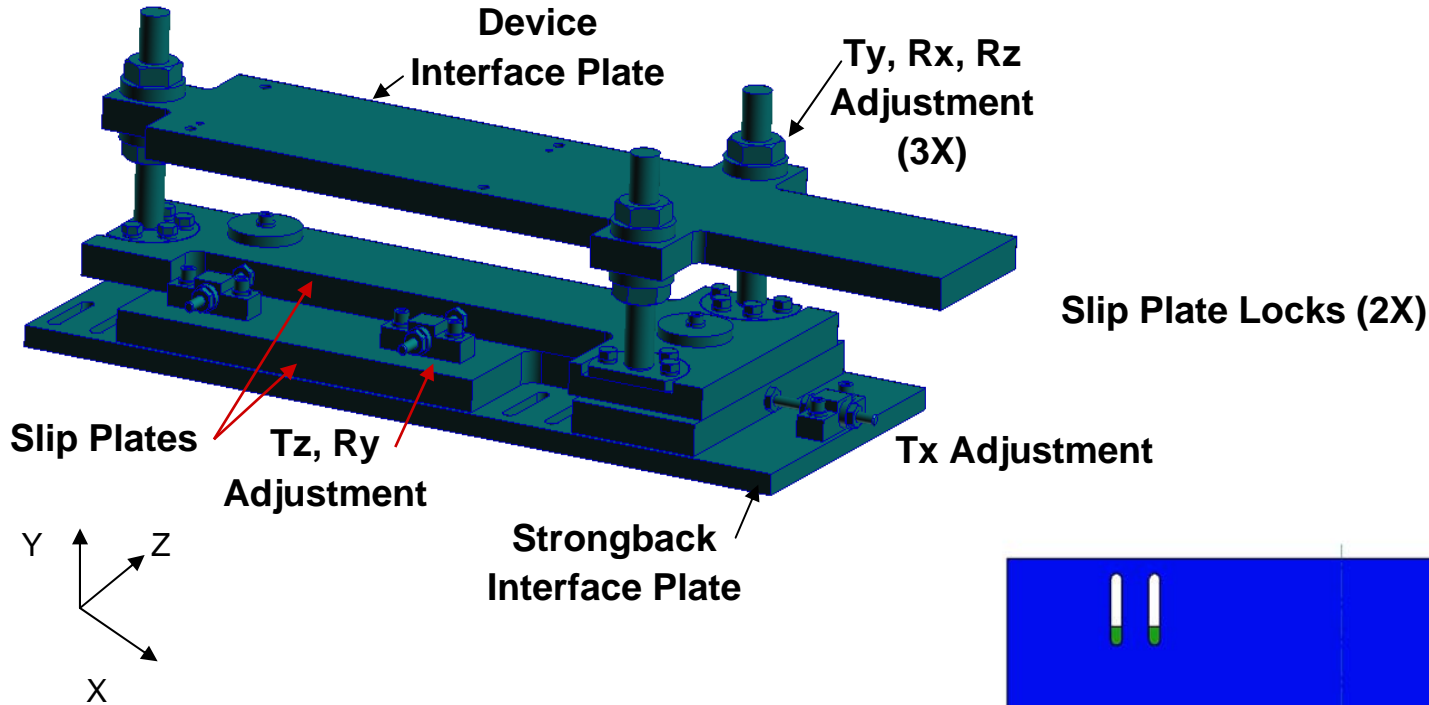

- Slotted interface per ICD SP-391-001-45

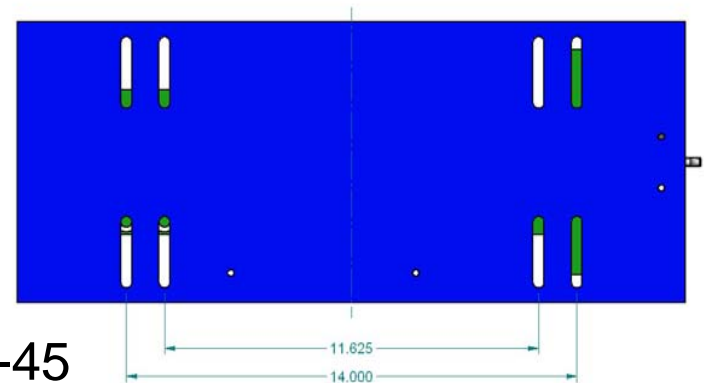

Operating Requirements

- Each filter must withstand the full FEL beam flux above 8.5 KeV. Attenuation per Figure 1 is required below 8.5 KeV.
- The XTOD Solid Attenuator will be used for the beam parameters that would cause filter damage.

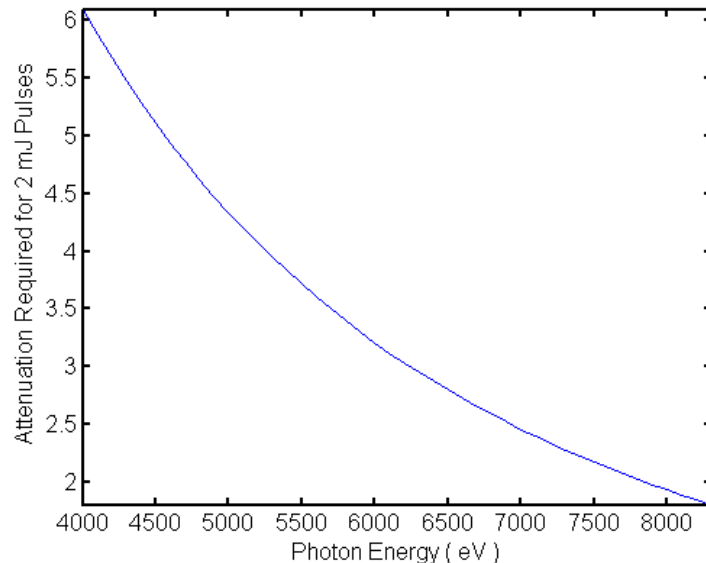

Attenuator-Pulse Picker PDR

Positioning Requirements

- In the “IN” position, each filter shall be centered on the x-ray beam axis within a 1 mm radius.
- In the “IN” position, the filter surface shall be normal to the theoretical beam centerline within $\pm 1^\circ$.
- In the “IN” position, a translational repeatability of 100 microns and angular repeatability of 0.1° shall be maintained.
- In the “OUT” position, a minimum stay clear radius of 12.7 mm from the theoretical beam centerline shall be maintained.
- The Attenuator design shall include a remotely operated mechanism for moving the filters to the IN or OUT position without breaking vacuum.
- The filter shall change state in less than 2 seconds.

Life Cycle Requirements

- Actuators will be cycled up to 3 times daily, 365 days a year for 10 years.
 - 10,000 cycles at 72 +/-5° F and 10⁻⁷ Torr pressure.

Analysis/Findings

- **Vibration:** The Attenuator vibration environment is a function of how the facility generated vibrations are transmitted through the Optics raft and the 6 degree of freedom mounting to the raft. In order to avoid interactions with lower frequency and higher amplitude facility vibrations, the Attenuator chamber shall have a fundamental mode of vibration greater than 120 Hz.

Chamber Modes

1st mode 170 Hz

2nd Mode 286 Hz

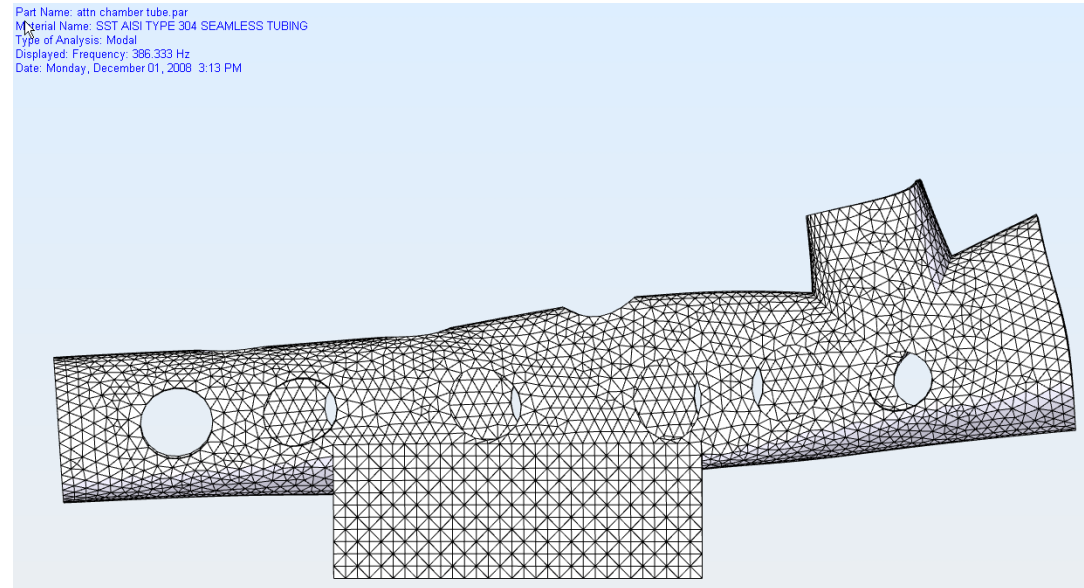
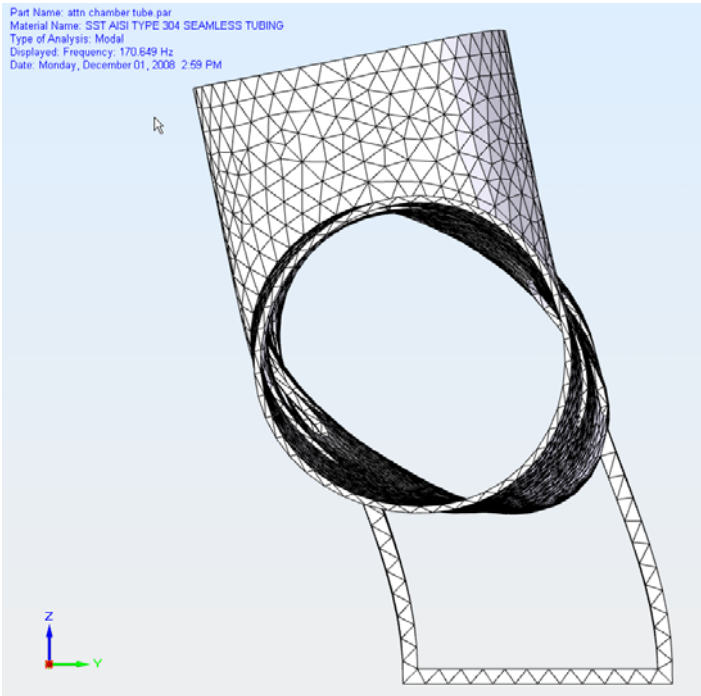

Attenuator-Pulse Picker PDR

Filter Actuator Modes

1st Mode 164 Hz Bending

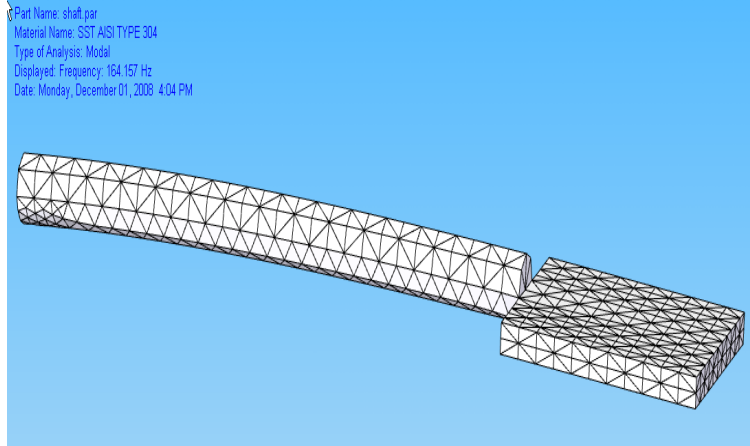

2nd Mode 165 Hz Bending

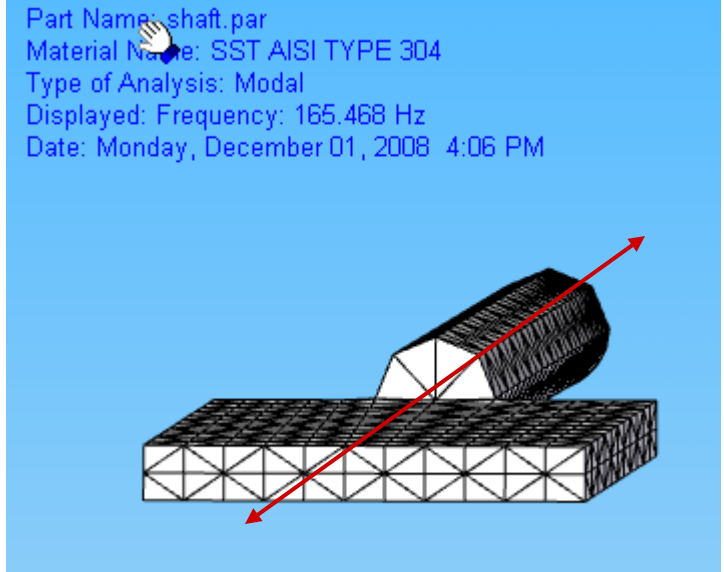

3rd Mode 1168 Hz Bending

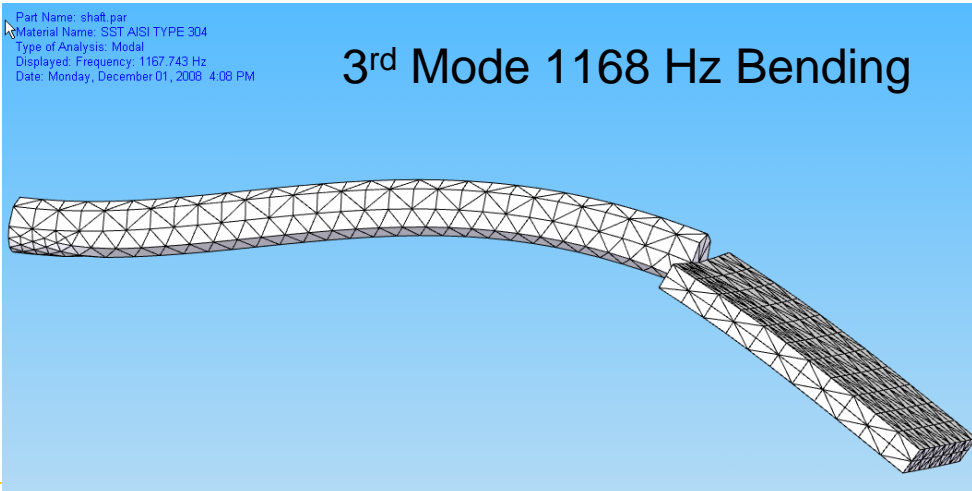

Attenuator-Pulse Picker PDR

Analysis/Findings (cont)

- Additional vibration requirements
 - Vibration amplitude @ freq > 1 Hz shall be < 10 μ m
 - Angular vibration amplitude @ freq > 1 Hz shall be < +/-0.1° in pitch & Yaw
- Expect to comply because
 - 1st mode of Optics Raft support plate is low (~1 Hz) so all frequencies above this are attenuated
 - 7 mechanical interfaces between floor and bottom of 6 degree of freedom support. Each one attenuates input.
 - Preliminary Near Hall vibration data showed integrated spectral density displacements 2 – 5 nanometers

Analysis/Findings (cont)

Thermal stability will comply

- Thermal expansion due to room temp delta of 2°F is 4.9μm and requirement is 50μm.

Radiation

- Filters withstand full FEL beam flux above 8.5 KeV
 - Comply per D. Fritz analysis
- Actuators survive 1 Krad/yr for 10 years
 - Expect to comply
 - No radiation sensitive components except possibly encoder

Proposed Test Programs

- Filter handling and clamping loads prototyping
 - Minimum filter order qty = 10 need 3, so have spares for test
 - Have purchased 6 - 100 μ m thick filters
- Actuator accuracy & repeatability
 - Borrow unit from vendor or buy 1 actuator
- Filter inspection with mirror system verification
- Cost & schedule impacts in work
 - Most hardware can be re-used

Interfaces

- Rotatable flanges on both ends of allow device to be rotated in beam line
- Attenuator bolts to (preliminary)
 - XPP: XFLS bellows and pump
 - XCS: Bellows on either side
 - CXI: Bellows on either side
- Interface between XPP strongback and 6 Degree of Freedom support is per ICD SP-391-001-45.
 - XCS and CXI are expected to provide similar interface.
- Electrical interfaces to Controls group
 - Stepper motors
 - Limit switches
 - Encoders

Controls

- Filter actuators are remotely operated
- Mirror actuators can be remotely or manually operated (TBR)
- Filter position status signal provided
 - Limit switches and stepper motor's encoder
- In the event of power failure, Stepper motor brake maintains filters last position
- Flow requirement for XTOD attenuation below 8.5 keV to protect filters to MPS
- Flow requirement to prevent mirror insertion when beam is on or to prevent beam turn on when mirror is IN to MPS.

Quality Control/Reliability

- QC
 - Material certificates required
 - Use SNAL established procedures for fabrication & assembly
- Reliability
 - Rely on vendor performance data – life cycles
 - No analysis planned

Safety

- No unique hazards
- Radiation concerns addressed at Instrument level
- Remote control of actuators and cameras
- Use of interlocks to protect filters & mirrors
- Feedback control for mirror prevents leaving it in beam

Schedule

- Attenuator design tasks pulled up ~5 months to support Pulse Picker first use on 3/29/10 (XPP)
 - PDR is 12/03/08; was 5/20/09
 - FDR is Mar 09; was 7/16/09
 - DSR is Jun 09; was 10/09/09
- Only the Chamber & 6 Degree of Freedom Mount are required for Pulse Picker operation on 3/29/10.
- Current Attenuator first use date is 10/4/10.
 - Can support 3/29/10 date if funding allows procurement of Attenuator elements to be pulled forward

Costs

- Attenuator is ahead of schedule and under budget

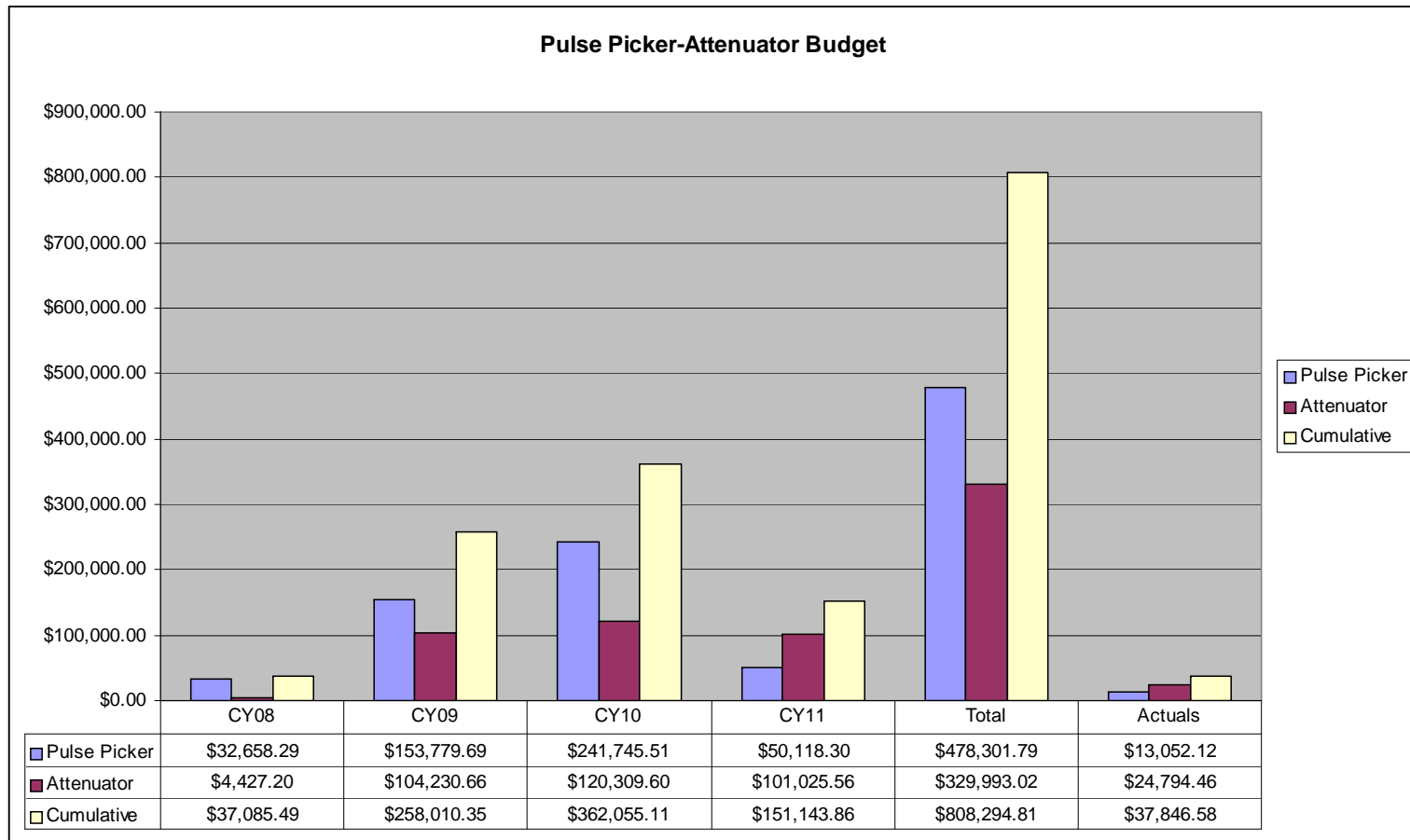

Attenuator-Pulse Picker PDR

Summary

- Attenuator design meets the Physics Requirements
- The ESD is complete and signed-off
- Cost-effective design uses commercially available hardware
- Design interfaces are identified and will be communicated to the relevant parties
 - Controls and software interfaces
 - Safety review committees
 - Instrument design teams
- Attenuator design allows for adjustment and maintenance
- Quality assurance is adequately addressed at this stage of design
- Accelerated schedule is possible and “Can only” option if problems
- **Attenuator design is ready to proceed to final design**
- **Review Committee should approve proceeding**

Action Items

Planned tasks for FDR

- Finalize actuator & holder designs for filters and mirrors
- Complete analyses
- Perform proposed Engineering tests

PULSE PICKER PDR

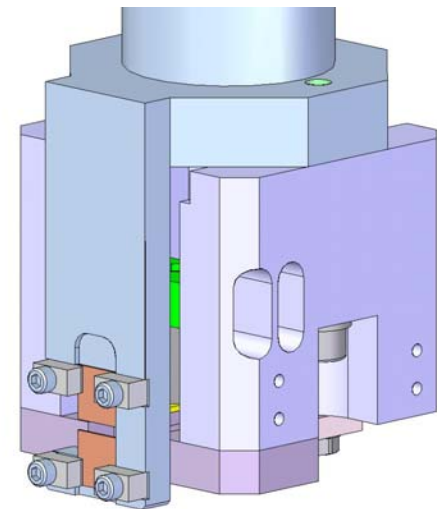
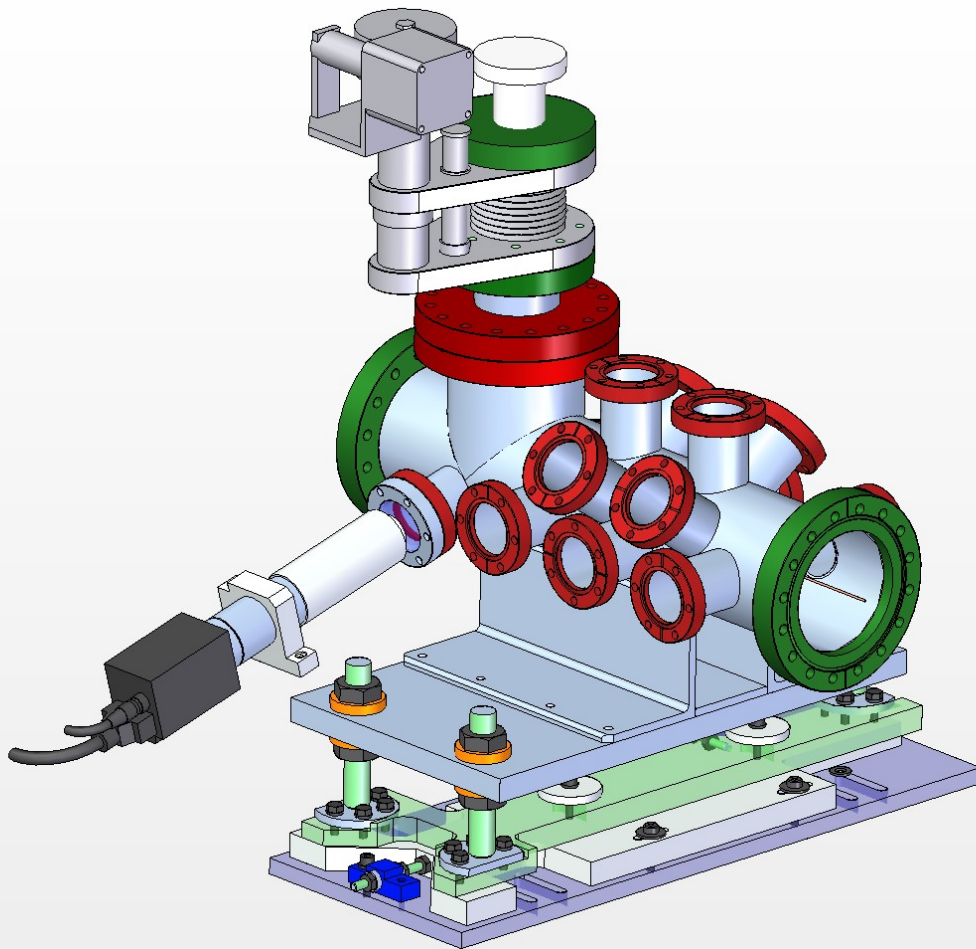

Attenuator-Pulse Picker PDR

Outline

- Science/technical objectives, requirements
- Pulse Picker Key Features
- Shutter Assembly Details/Z Stage Assembly
- Operating/Positioning/Life Cycle/Thermal Requirements
- Preliminary Engineering Analyses/Findings
- Test Program
- Design interfaces
- Control/software requirements
- Quality control, reliability
- Safety
- Schedule & Costs
- Summary
- Action Items

Science Objectives/Requirements

- Pulse Picker reduces the repetition rate of the LCLS pulse train from 120 Hz to 10 Hz or lower.
- The expected use is to provide a single pulse to a sample every 30 to 120 seconds
 - depending on the rate samples can be changed

Pulse Picker Key Features - 4 slides

- Shutter Assembly
- Up beam shields define aperture into Shutter Assembly
- Down beam shields to block reflections off flapper
- Y stage to move Shutter Assembly into and out of the beam
- Camera to view shutter operation remotely, if required

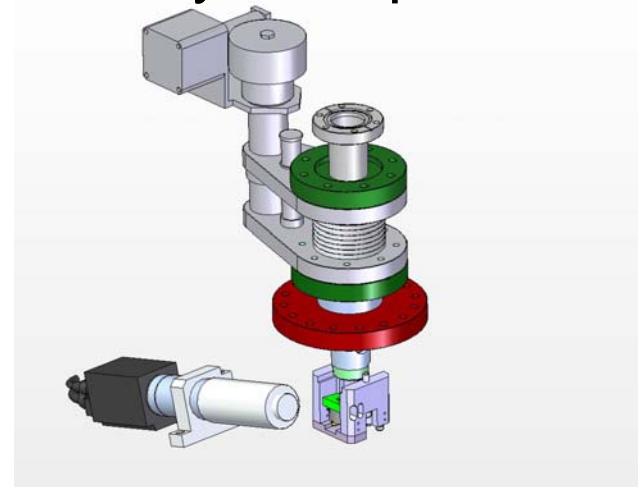

Attenuator-Pulse Picker PDR

Pulse Picker Key Features - 1

- Shutter Assembly

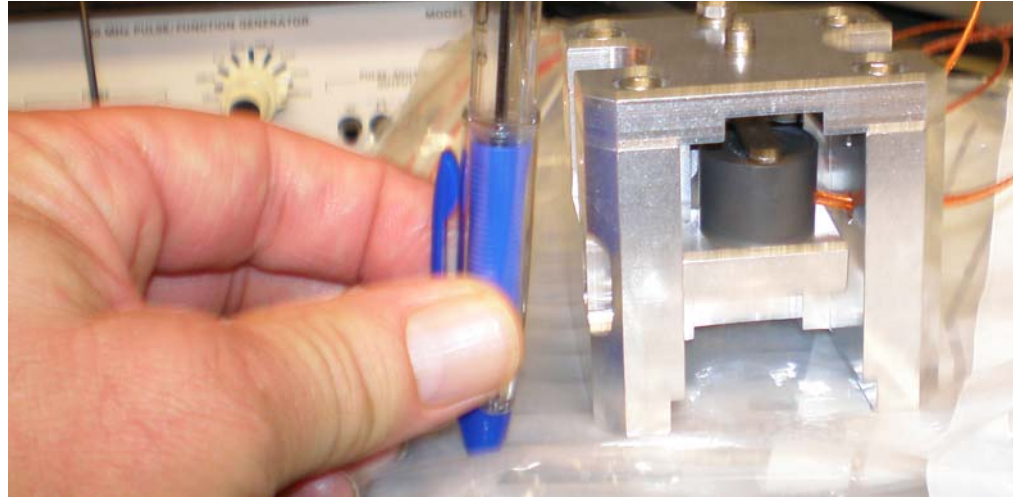
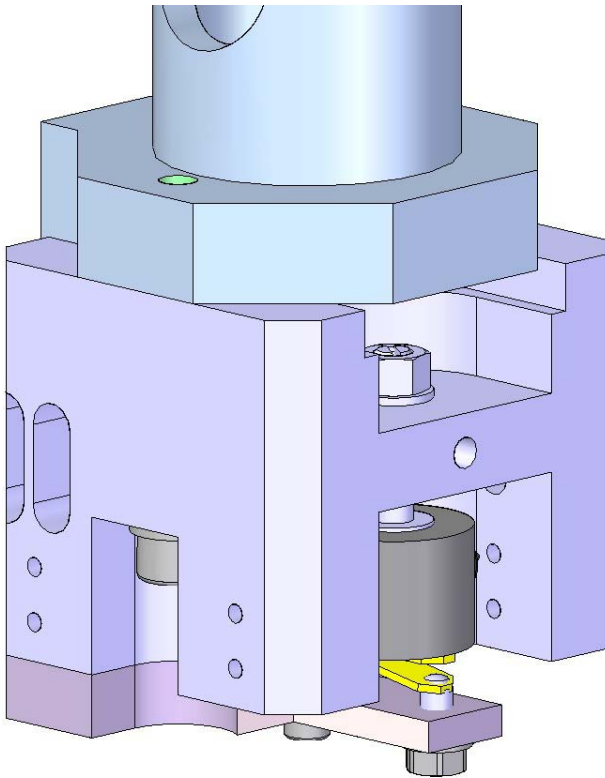

Shutter Assy dims
Roughly 2 ¼ in.
Square cube



Attenuator-Pulse Picker PDR

Pulse Picker Key Features - 2

- Up beam shields define aperture into Shutter Assembly

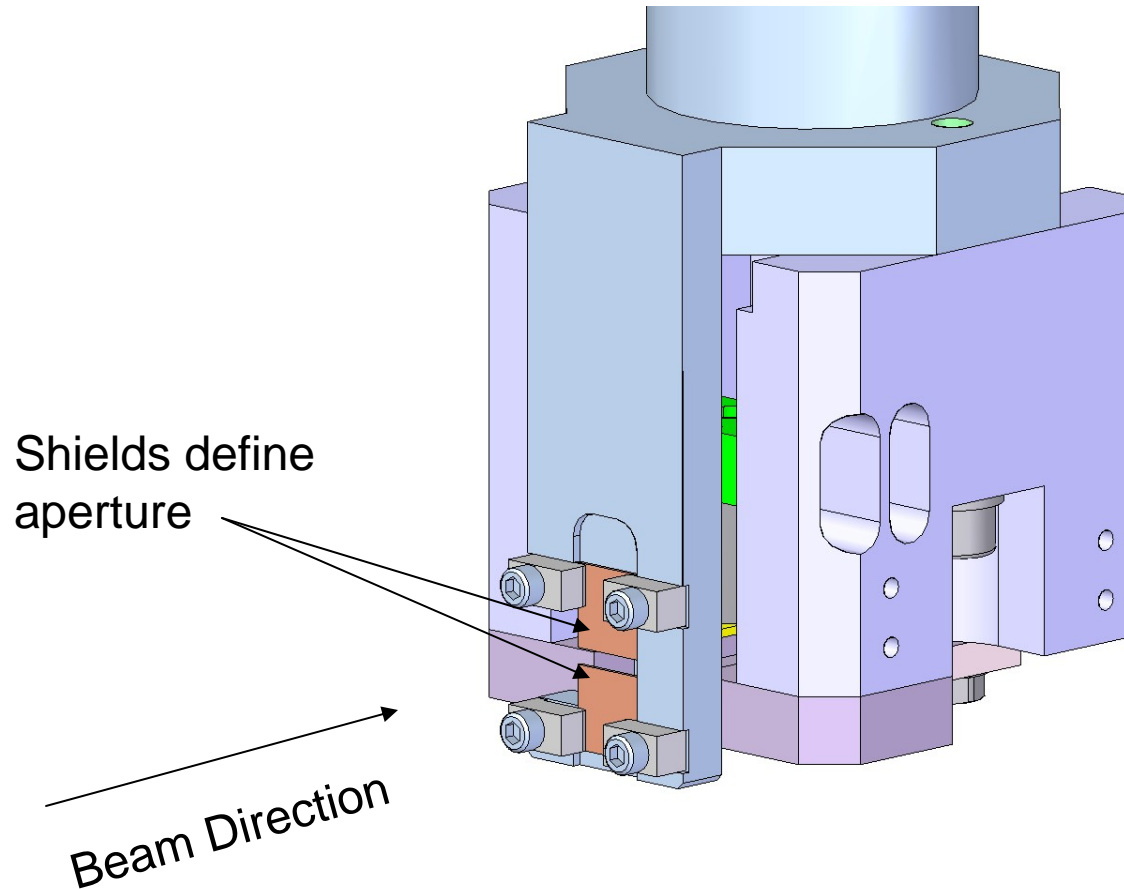

Attenuator-Pulse Picker PDR

Pulse Picker Key Features - 3

- Y stage to move Shutter Assembly into and out of the beam

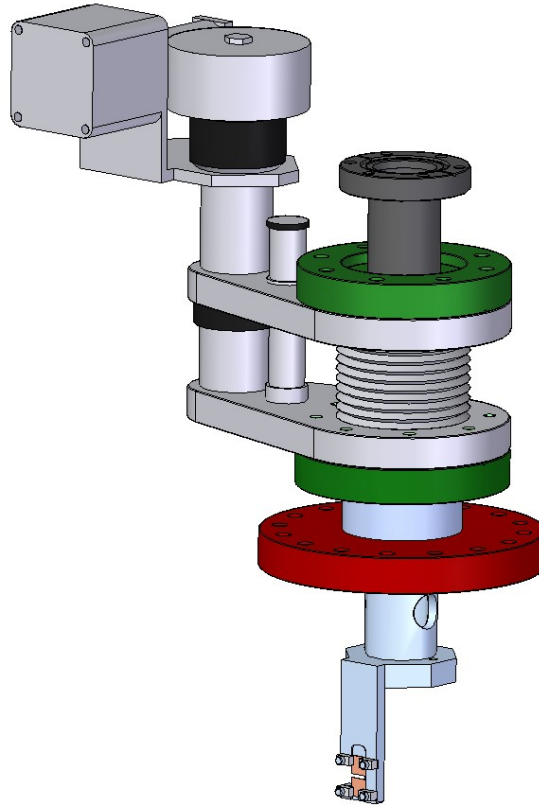

Attenuator-Pulse Picker PDR

Pulse Picker Key Features - 4

- Camera to view shutter operation remotely, if required

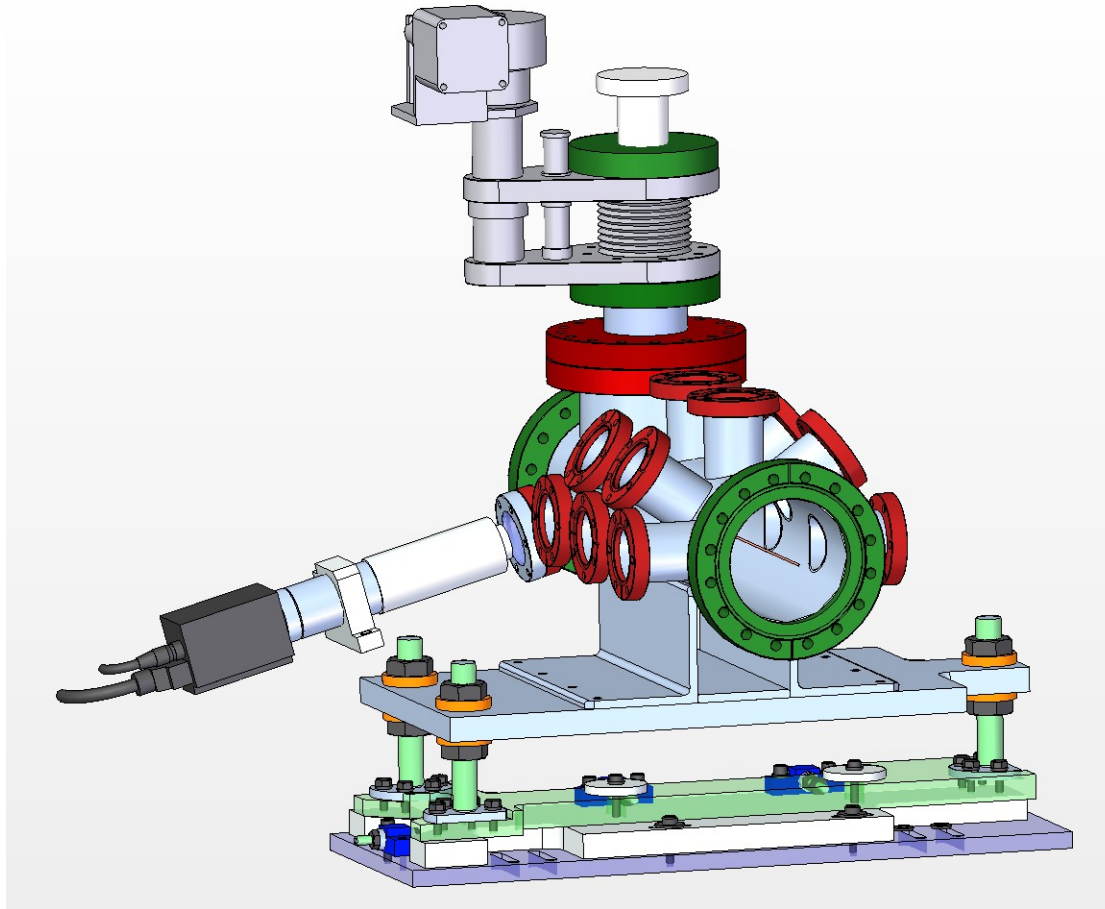

Attenuator-Pulse Picker PDR

Shutter Assembly Details – 6 slides

- Purchased part from Azsol
- Iron “Flapper” (Shutter) rocks between pair of magnets
- Shutter has Silicon Nitride plates brazed onto it
- Shutter magnet wires pass through the ID of the actuator shaft to a standard electrical vacuum feed through
- Shutter cover notched to allow viewing of flapper

Shutter Assembly Details - 1

- Iron “Flapper” ([Shutter](#)) rocks between a pair of magnets
 - 6 mm cross section at low grazing angle
 - Beam transmission $< 10^{-11}$ through flapper

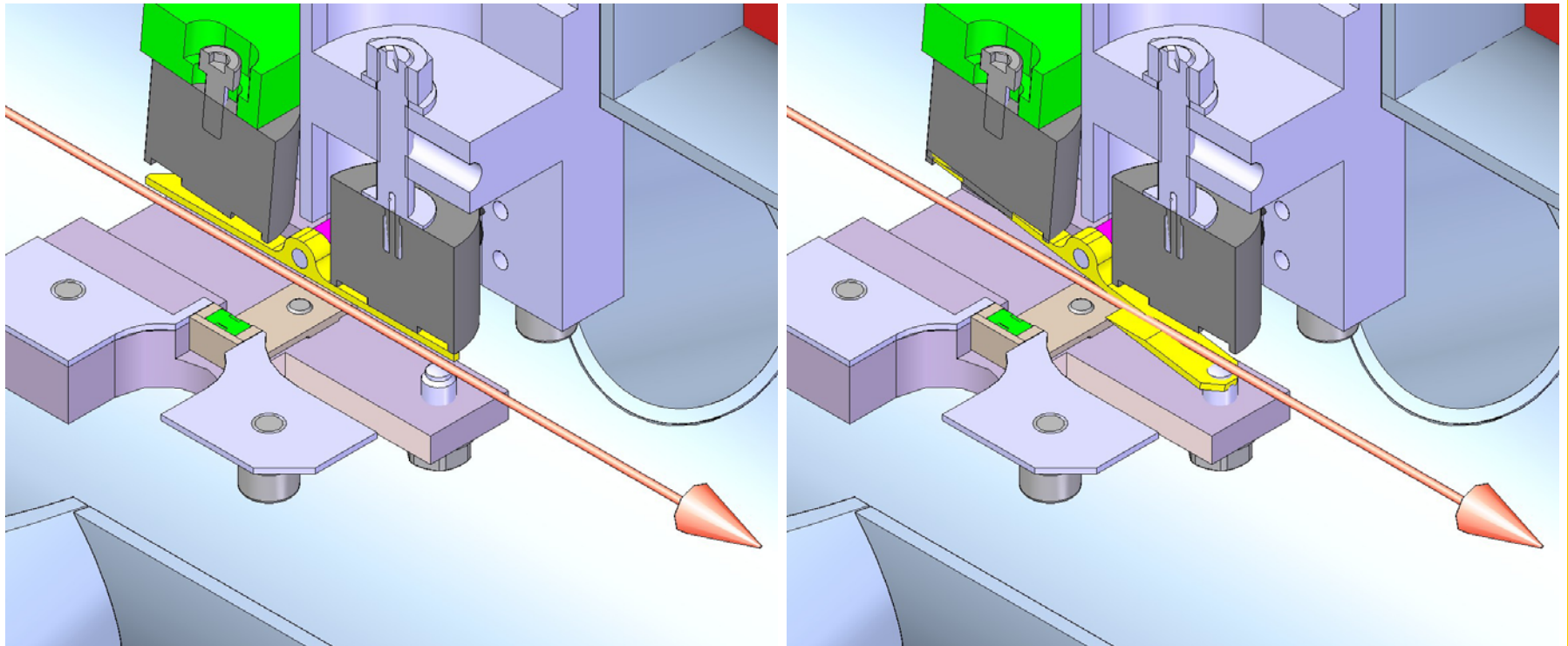

Attenuator-Pulse Picker PDR

Shutter Assembly Details - 2

- Shutter has Silicon Nitride plates brazed onto it (Dwg)
 - Silicon Nitride attenuates beam by a factor of 100
 - Allows flapper to remain in beam without damage
 - Copper layer to combat delta in Coefficient of Therm. Exp.
 - Min weight increase (23%) to shutter in order to minimize neg. impact on shutter operation

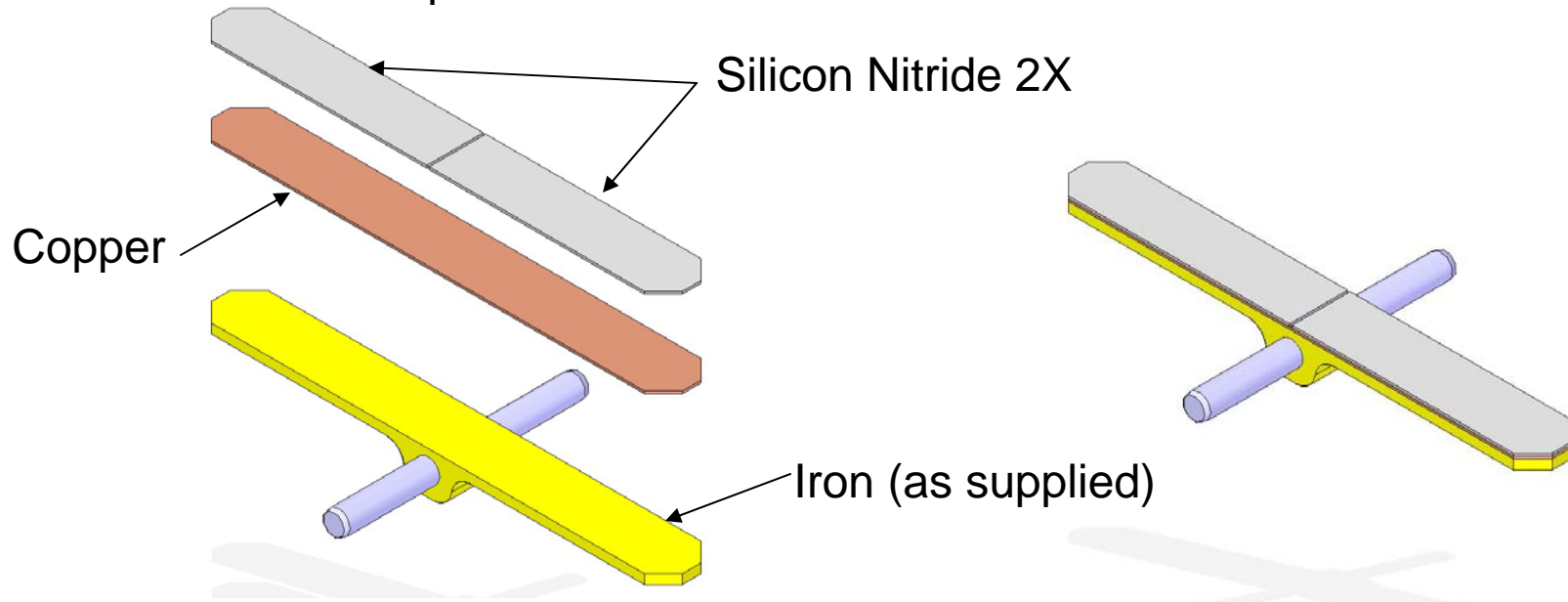

Attenuator-Pulse Picker PDR

Shutter Assembly Details - 3

- Magnet wires pass through ID of shaft to standard electrical vacuum feed through

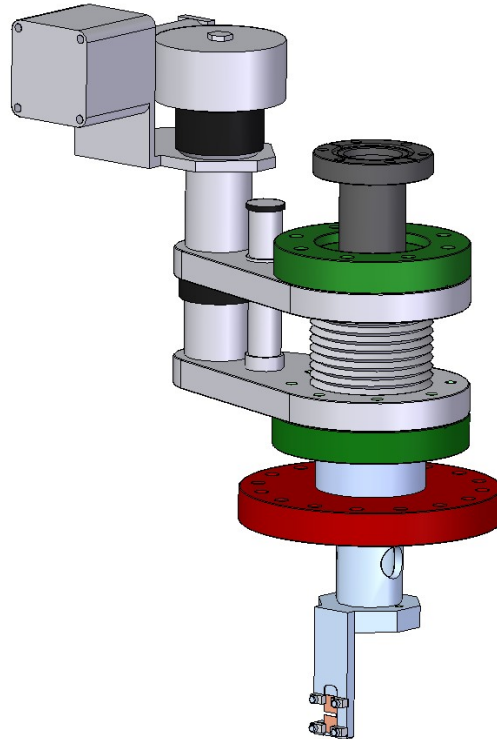

Attenuator-Pulse Picker PDR

Shutter Assembly Details - 4

- Cover notched to allow viewing of flapper

Standard Cover

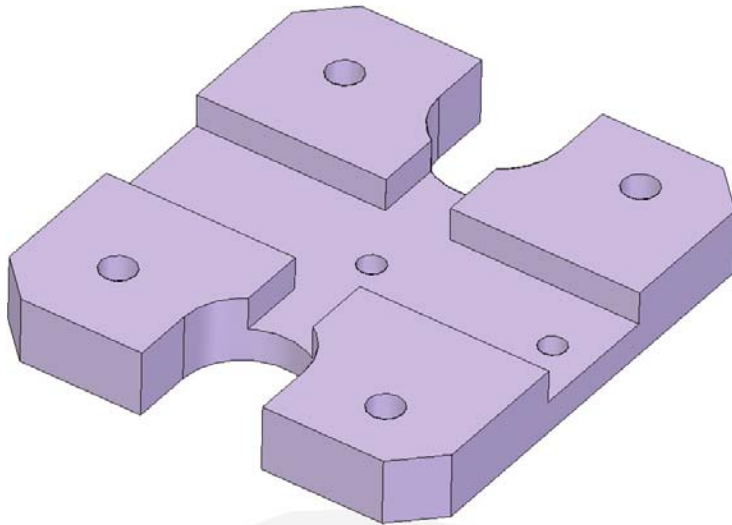

Modified Cover

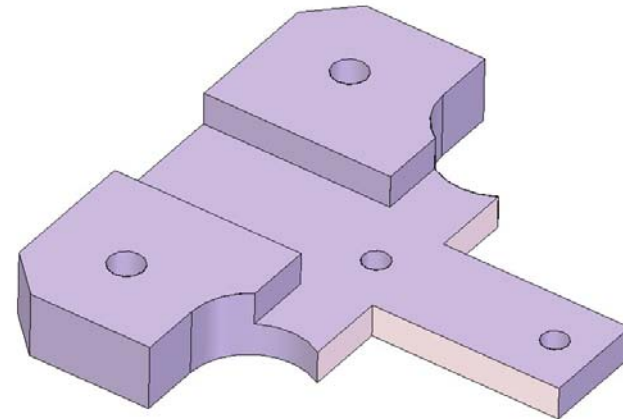

Shutter Assembly Details - 5

- Cover notched to allow viewing of flapper

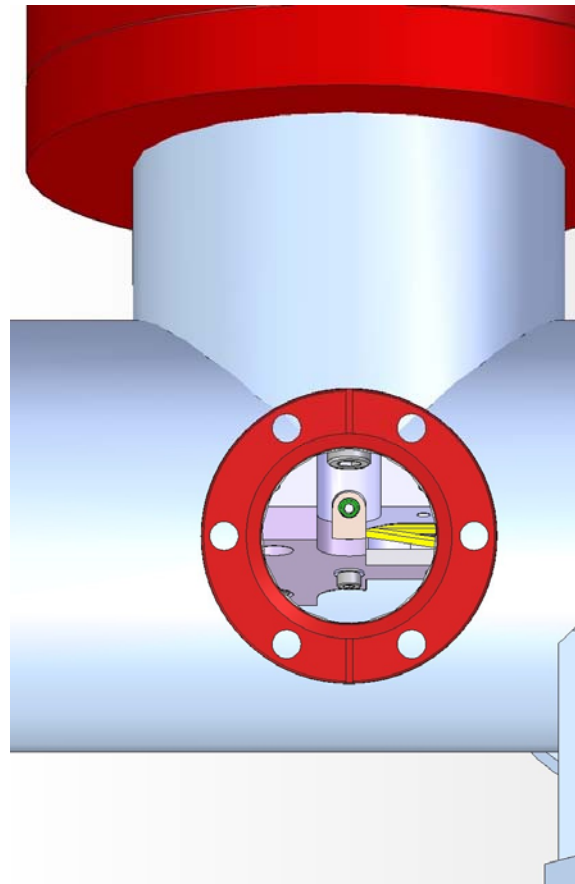

Attenuator-Pulse Picker PDR

Shutter Assembly Details - 6



Open



Closed 4mm
max. 3mm beam

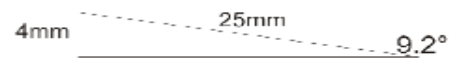

Absorption Material
1mm thick

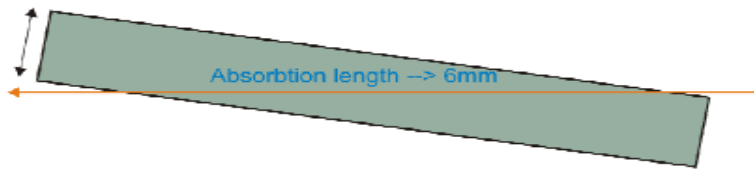

9.2° (4mm-version)

4mm-version → 6mm Fe absorber

Attenuator-Pulse Picker PDR

Z Stage Assembly

- 6 inch CF Flange to mount assy
- MDC vertical stage w 2 in stroke (TBF)
- Electrical feedthru for magnet wires
- Stepper Motor
- Accuracy of 50 microns is achievable with many off the shelf Z stages

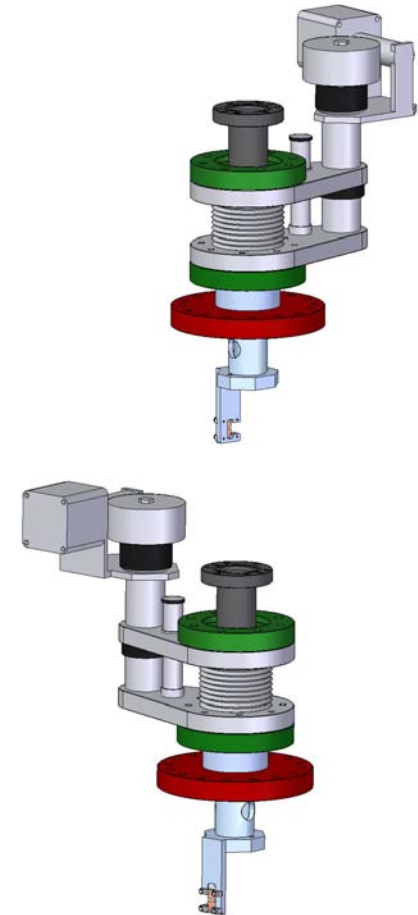

Operating Requirements

- Reduce the repetition rate of the LCLS X-ray pulse train to any frequency from zero Hz to 10 Hz.
- An opening time and closing time of 3 msec or less.
- Perform one open and close cycle in less than 8 msec.
- Remain open or closed for as long as desired.
- Withstand the full LCLS flux (white beam) at all locations downstream of and including NEH Hutch 2, across the 2-25 keV spectral range without degradation due to radiation damage.
- The transmission through the Pulse Picker, with the shutter in the closed position, shall be no more than 10^{-11} throughout the entire spectral range of 2-25 keV.
- Reflection of the beam off the Pulse Picker shall not be allowed to propagate down the beamline.

Positioning Requirements

- When in the “IN” position, the LCLS beam shall propagate through the center of the Pulse Picker aperture within 50 microns.
- The accuracy and repeatability of the “IN” position of the Pulse Picker aperture shall be less than or equal to 50 microns.
- In the “OUT” position, a minimum stay clear radius of 12.7 mm from the theoretical beam centerline shall be maintained.

Life Cycle Requirements

- The vertical linear actuator on the Pulse Picker may be cycled up to 5 times daily, 60 days a year for 10 years (or roughly 3,000 cycles) at 72 +/-5° F and 10⁻⁷ Torr pressure.
- The shutter mechanism on the Pulse Picker may be cycled up to 10,000 times daily (16.7 minutes at 10 Hz), 60 days a year for 10 years (or roughly 6 million cycles) at 72 +/-5° F and 10⁻⁷ Torr pressure.
- The shutter frequency can be anywhere from zero to ten Hz, but for the majority of the run time the shutter will be running in the 0.01 Hz to 1.0 Hz range.

Thermal Requirements

- The Pulse Picker Shutter shall be able to withstand, without degradation, a heat load of 240 mW from the X-Ray beam.

Analyses/Findings

- Calc Natural freq of shaft with mass > 222 Hz (see slide)
- Thermal expansion due to room temp delta of 2°F is 4.9μm and requirement is 50μm
- Vibration stability (covered in attenuator slides)
- Silicon Nitride thickness calc – 70 microns (S.B.)

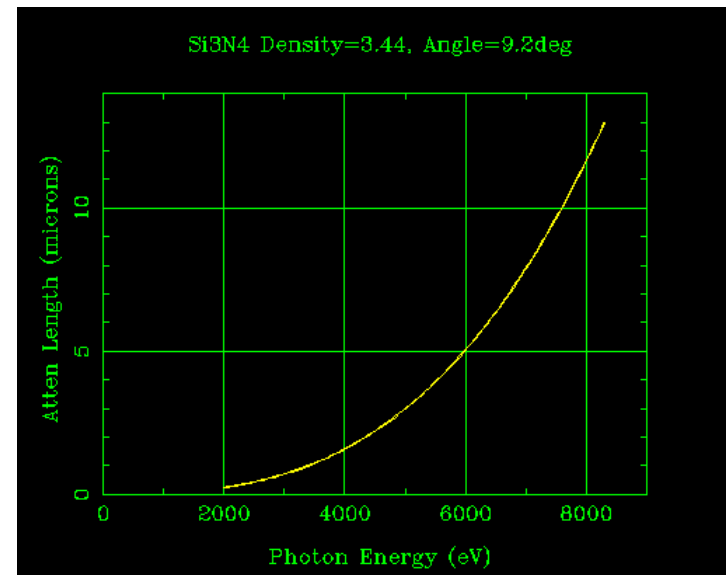

Attenuator-Pulse Picker PDR

Analyses/Findings

- Iron transmission thickness calc – 1mm at 9.2° (or 6mm) (S.B.)

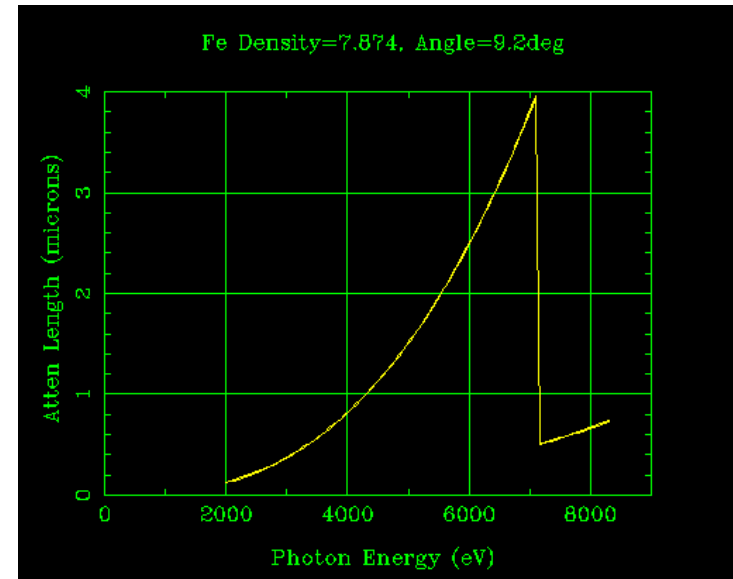

- Thermal testing of shutter (due to 240mW impingement)
 - Planned for Jan09- test w 240mW heat source in vacuum with thermocouples

Stage Shaft Modes

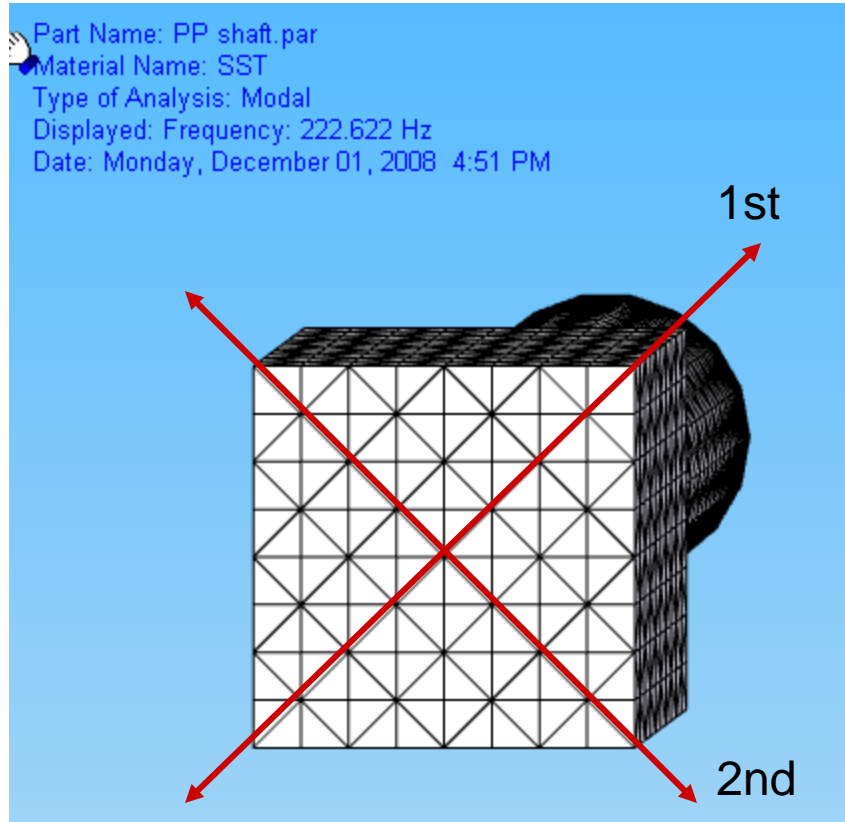

1st mode = 222.62 Hz bending
 2nd mode = 222.64 Hz bending

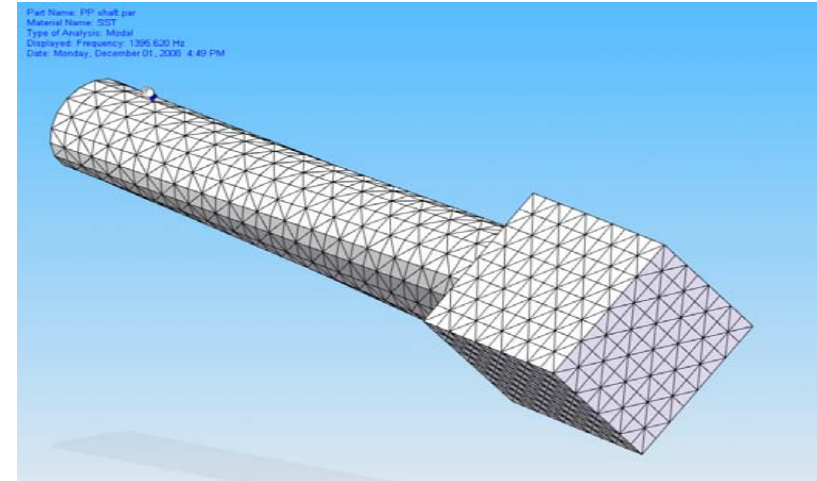

3rd mode = 1395 Hz twisting

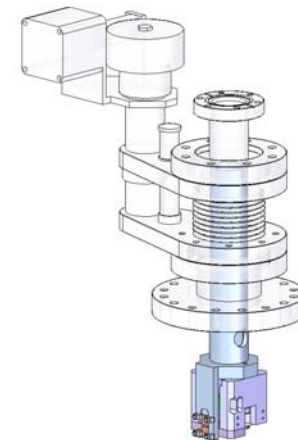

Test Program – 1 slides

- Perform Vendor Acceptance Test under various conditions
- Look for performance variations – opening/closing time
- Possible failure modes
 - Magnetization of flapper
 - Flapper bearing lubrication failure
 - Silicon Nitride flaking from impacts against stop bolt
 - Silicon Nitride braze joint failure or cracking
 - Kapton tape of backside of flapper might de-bond
- Determine the expected life of the units (shutter assemblies)

Test Program - 1

- Tests to evaluate the main deviations from Vendor experience (coated, upside down & in vacuum)
- Vendor has data out to 5M cycles at 0.03 Hz (one pulse every 30 seconds)
- “Failure” defined on previous chart

Test #	Test Configurations			~7 Hrs/test
	Flapper	Orientation	Pressure	# cycles at 10 Hz
Baseline	as supplied	normal	ambient	250K
2	as supplied	upside down	ambient	250K
3	as supplied	normal	vacuum	250K
4	as supplied	upside down	vacuum	250K
Baseline coated	Si ₃ N ₄ coated	normal	ambient	250K
2 coated	Si ₃ N ₄ coated	upside down	ambient	250K
3 coated	Si ₃ N ₄ coated	normal	vacuum	250K
4 coated	Si ₃ N ₄ coated	upside down	vacuum	250K
Life Test	Si ₃ N ₄ coated	upside down	vacuum	to failure*
May take data at other expected operating frequencies				

Test Set Up from Azsol

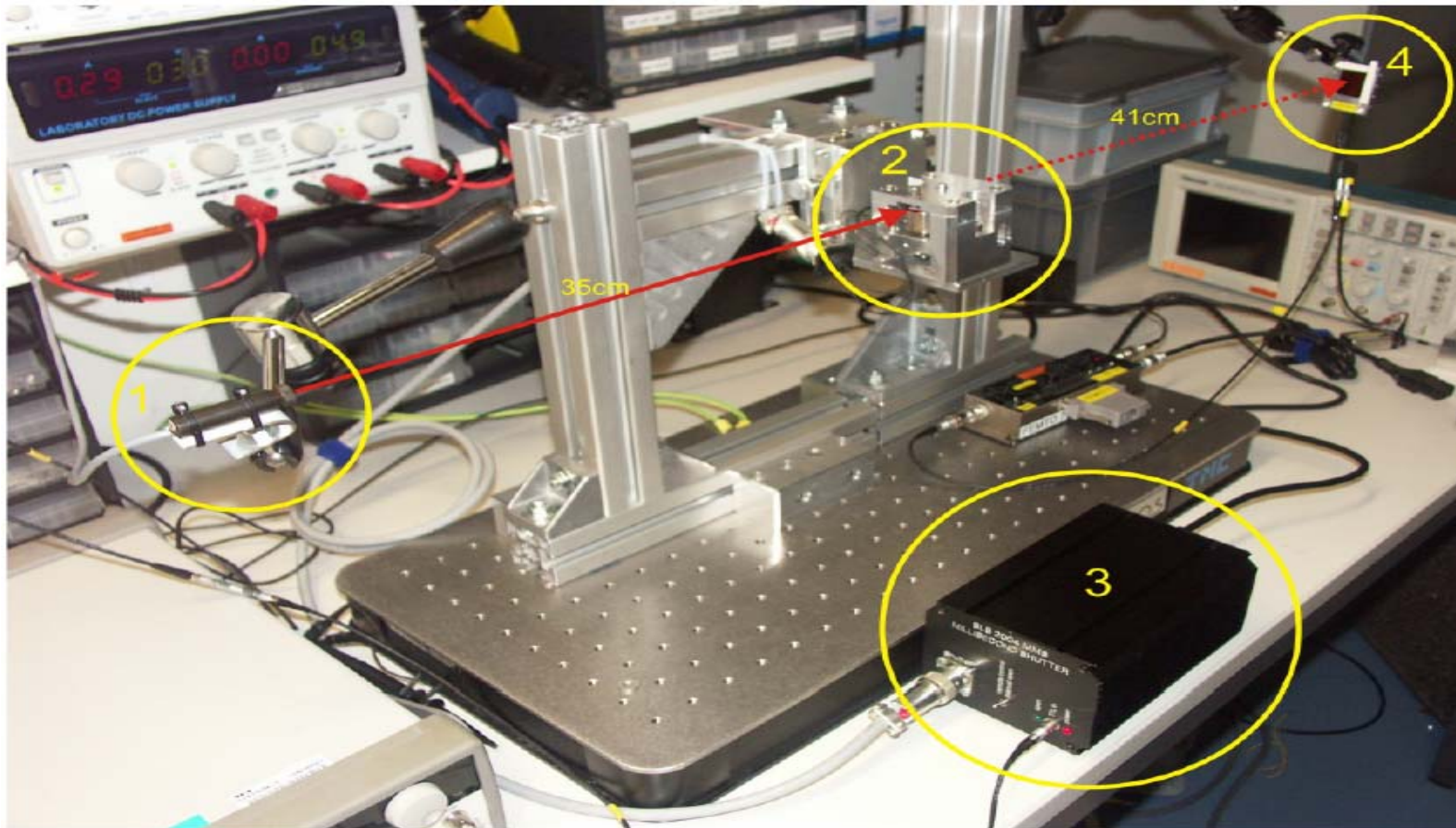
**1 Laser****2 Shutter****3 Driver****4 Diode**

Attenuator-Pulse Picker PDR

Interfaces

- Attenuator chamber 6" OD CF flange
- Electrical interfaces to Controls group (plus items on next 2 slides)
 - Shutter Assembly Driver Box
 - Remote control
 - Data out port
 - Stepper motor
 - Limit switches
 - Encoders

Controls

- A video signal showing the view of the Pulse Picker shutter actuation status (open, closed or actuating) is required on the Pulse Picker located in the XRT and will be obtained via an appropriately mounted video camera.
- The state of the all Pulse Picker shutters and shutter speeds/frequencies shall be recorded in the experimental metadata.
- The status of the vertical positioning stage of all Pulse Pickers shall be recorded in the experimental metadata.

Controls (cont)

- Coordination is required between the PPS Photon Stopper and the Pulse Picker, via a signal, such that anytime the shutter is left in the closed position, with the beam impinging upon the shutter, for a period of time greater than TBD minutes, that the PPS Photon Stopper will be signaled to stop the beam.
- Coordination is required between the PPS Photon Stopper and the Pulse Picker, via a interlock, such that anytime the shutter is signaled to move out of or into the beam path the PPS Photon Stopper will be signaled to stop the beam.

Quality Control/Reliability

- QC
 - Material certificates required
 - Use SNAL established procedures for fabrication & assembly
- Reliability
 - Rely on vendor performance data – life cycles for Y stage and bellows
 - Perform life test on Shutter Assembly Engineering unit
 - No analysis planned

Safety

- No unique hazards
 - (Concern- 100 Vdc requirement to the shutter magnet coils)
Above 50 Vdc puts the issue on the safety “radar screen”
- Radiation concerns addressed at Instrument level
- Remote control of actuators and cameras
- Use of interlocks to protect Shutter Assembly

Schedule

- Pulse Picker first use on 3/29/10 (XPP)
 - PDR is 12/03/08
 - FDR is 03/XX/09
 - DSR is 6/XX/09

Costs

- Pulse Picker is on schedule and under budget

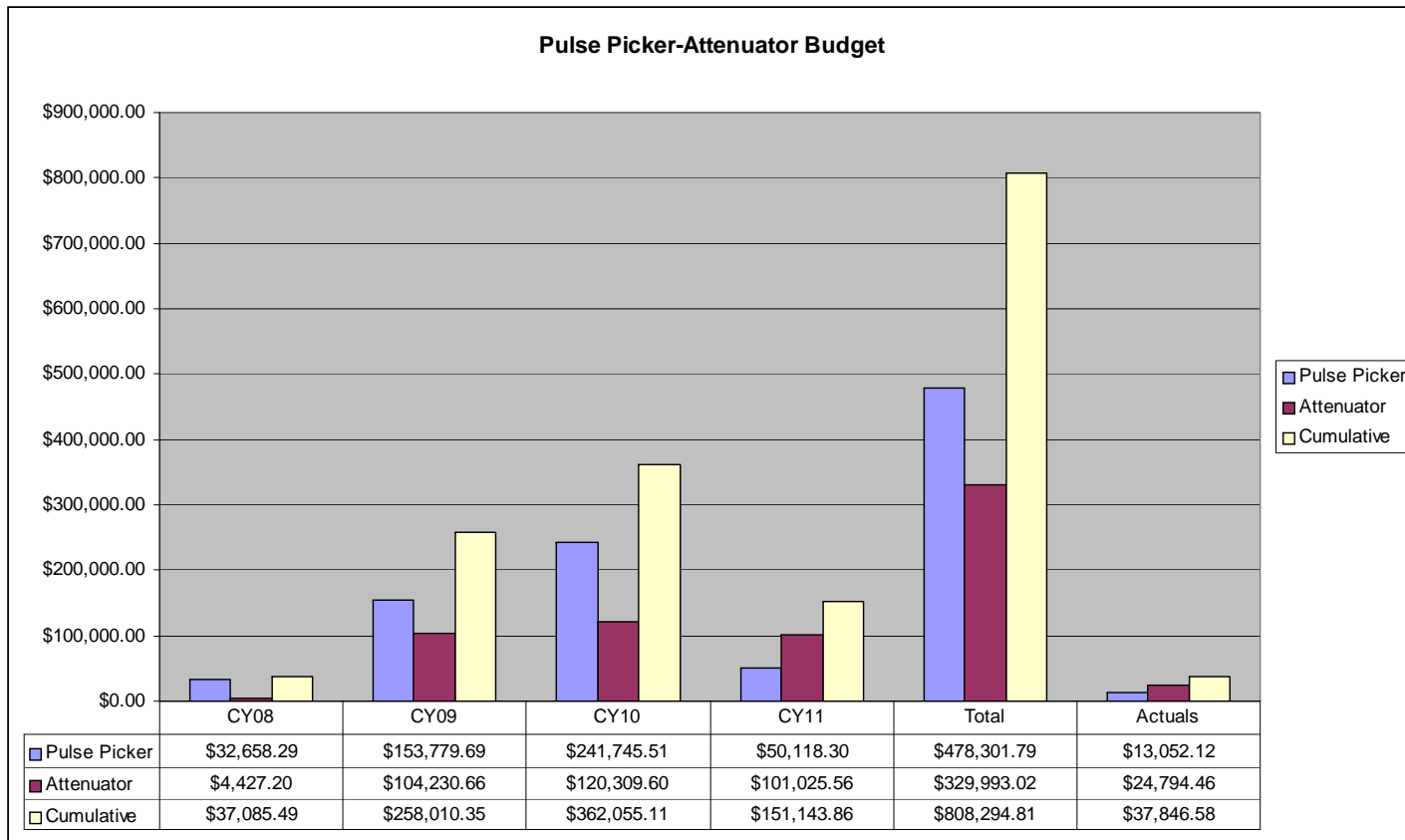

Attenuator-Pulse Picker PDR

Summary

- The Pulse Picker design does meet the Physics Requirements
- The ESD is complete and already being signed-off
- The design cost-effective
- Design interfaces are identified and will be communicated to the relevant parties
 - Controls and software interfaces
 - Safety review committees
 - Instrument design teams
- The Pulse Picker device is constructible and maintainable
- Quality assurance is adequately addressed at this stage of design
- The cost estimate is reasonable & the schedule is tight, but possible
- **The Pulse Picker device design is ready to proceed to final design with Review Committee approval**

Big Picture Pulse Picker Action Items

- Quickly move towards final design
- Thermal testing of shutter
- Verification of Silicon Nitride Brazing concept
- Confirm use of MDC Z stage or chose another



LCLS Ultrafast Science Instruments

DESIGN REVIEW REPORT		Report No. TR-391-003-13-0
The Design Review Report Shall include at a minimum: <ul style="list-style-type: none"> ▪ The title of the item or system; ▪ A description of the item; ▪ Design Review Report Number; ▪ The type of design review; ▪ The date of the review; ▪ The names of the presenters ▪ The names, institutions and department of the reviewers ▪ The names of all the attendees (attach sign-in sheet) ▪ Completed Design Checklist. 		<ul style="list-style-type: none"> ▪ Findings/List of Action Items – these are items that require formal action and closure in writing for the review to be approved. See SLAC Document AP-391-000-59 for LUSI Design Review Guidelines. ▪ Concerns – these are comments that require action by the design/engineering team, but a response is not required to approve the review ▪ Observations – these are general comments and require no response
TYPE OF REVIEW: Preliminary Design Review		
WBS: 1.5 Diagnostics Common Optics		
Title of the Review	Attenuator and Pulse Picker Preliminary Design Review	
Presented By:	Dave Fritz, Marc Campell, Rick Jackson	
Report Prepared By:	Martin Nordby	Date: 12-03-08
Reviewers/Lab :	Scott Debarger (SLAC) Rob Duarte (LBL) Martin Nordby (SLAC) Andy Ringwall (SLAC),	
Distribution:		
Attachments:	<input type="checkbox"/> Review Slides <input type="checkbox"/> Design Checklist <input type="checkbox"/> Calculations <input type="checkbox"/> Other	
Purpose/Goal of the Review: <ul style="list-style-type: none"> • Assess the completeness of physics and engineering requirements for the Attenuator and Pulse Picker. • Review the preliminary design of the Attenuator/Pulse Picker system and evaluate how well it meets the requirements • Review the interfaces that have been identified and how well they have been communicated to the relevant parties (includes controls and software interfaces, safety review committees, instrument design teams) • Assess plans for fabrication, assembly, testing and inspection, and maintenance • Review the cost estimate and schedule. • Identify high-risk elements and evaluate plans to mitigate the risk. 		
Comment on whether the component design is ready to proceed to final design		

Introduction and outcome summary of the review:

The review presenters were prepared and clearly knowledgeable. There was a good explanation of the rationale driving some of the key science requirements, although a number of the lower-level requirements seemed to have little quantitative back-up.

The decision to combine the Attenuator and Pulse Picker into a single chamber appears prudent and has borne significant fruit in freeing up many inches of beamline.

In general, the design of both systems is very modular, making use of off-the-shelf components and providing significant flexibility in how the systems are brought on-line and used. This should also help to recover from any schedule slips or production problems, since parts should be able to be added after initial commissioning is complete.

The review committee feels that in general the preliminary design that was presented is sound, requirements are understood, and a development schedule is in place to advance the design through FDR and into production. We recommend that the prototype program advance at full speed and that the Attenuator and Pulse Picker team proceed to final design.

Findings/Action Items:

None

Concerns:General

Prototypes were planned for the shutter flapper and attenuator filter drive system. However, FDR is planned in March, 2009 so there is little time to respond to problems that arise during the prototype program.

Attenuator

Attenuator appears to provide protection for x-ray detectors, but this is not part of the controls paradigm. This requirement should be clarified, since it may affect controls functionality. There was an understanding that this should not be part of the MPS/beam abort system, but there is apparently real hardware that needs real protection, so the protection paradigm should be clarified.

Controls implications of the attenuator are not fully understood as related to how a large dose could crack a silicon filter. The damage threshold will need to be determined during operation. However, there may be implications on the control system. This would not be part of the machine protection system (which dumps the e-beam) but it is not clear how protection would be established.

Positioning and adjustment system for the filters seems cumbersome, given that there will be 30 filters for the 3 chambers. The z-position and rotation are both set by a stud-end on the shaft and a jam nut. Look into simplifying the adjustment so it is easier to make incremental changes without shimming. Also, think about a test stand to adjust these out of the chamber. This may be important if the pulse picker goes in first (with the chamber) since the filter assemblies won't

have a chamber to mount to.

The insertable inspection mirror for filters needs to be interlocked to the beam system. It wasn't clear that this is being planned for and what interlock is needed (hard beam abort or some software acknowledge or status signal).

Filter inserted position repeatability of 100 microns sounds tight and may be an over-spec. The implications on the limit switches, encoder, and feedback control have not been understood, and there is a good chance that this will be hard to achieve.

Requirement for 10,000 cycles will likely force a different material choice for the bellows. This is a conservatively high value, but needs to be thought out in conjunction with the bellows material cyclic fatigue issue.

Shutter

Thermal stresses in the shutter flapper will likely be high, both due to brazing and beam impingement during operation. There has not been any analysis of this, and the design looks like it will have problems with this. There is a P.O. out for brazing prototypes right now, which should address some of the manufacturing problems.

It would be worthwhile to develop some fallback options for the flapper design, since this looks to be a high-risk item. Ideas include low-temperature brazing, soldering, or epoxying. . If there are issues with the prototype brazing, perhaps a ferromagnetic material, like Kovar, could be substituted for the flapper and brazed directly to the Silicon Nitride. A low temperature, fluxless, vacuum compatible brazing process is described in SSRL engineering note M386 (D. Van Campen)

→Do thermal distortion analysis of the tri-material flapper with 240 mW and radiative cooling off the silicon nitride and iron. There is a test planned, also, but this analysis should inform the test planning, and the test should verify the analysis.

Need to spec an allowed thermal distortion of the flapper.

The power dissipation of the solenoids was not presented. Design should provide for adequate heat transfer to prevent overheating and reduced life. Maybe Azsol has guidelines.

Mechanical alignment req. of the shutter flapper is 50 microns, which is too tight to get with conventional metrology. However, the shutter alignment will be done with an attenuated beam, so this requirement is not needed. What IS needed is the ability to move the hard stop to position the shutter over a broad range as part of the beam-based alignment. We suggest reviewing both the requirements and alignment plan to plan for the beam-based alignment while ensuring that the capabilities for adjustment are included in the design.

The cyclic lifetime of the off-center drive system will likely be poor, since the linear bearing is

eccentrically loaded. This will result in more play and less positional accuracy towards the end of life which could impact the alignment requirements and plans.

Remove the adjustment screw on the silicon-nitride side of the shutter flapper to prevent it from impacting on the silicon nitride and to prevent over-constraining the shutter against the stop, at the pivot point, and to the solenoids. Solenoids are adjustable, so this is how the flapper pivot angles are set.

The only feedback on the shutter position is with the camera. Look into adding limit switches, continuity monitors, proximity switches, or inductance monitors so the flapper position is always known. This may not be required, but seems prudent for troubleshooting problems. Since there was concern voiced about the possibility of the iron flapper magnetizing and sticking to one solenoid, it seems that instrumentation to monitor the location of the flapper could be useful to track problems.

Observations:

General

Pulse picker and Attenuator were combined into one chamber in summer 2008, with almost 11” of beamline saved. This forced an advance in Attenuator schedule by ~5 months, which has reduced schedule margins, but not significantly raised the risk of missing the first installation milestone of 3/2010. The Attenuator filter assemblies can be installed relatively easily, so even if they are late, the work to retrofit an already-installed unit should be relatively straightforward.

Stepper motors are the standard actuator, to standardize the controls system. Pneumatics would likely be cheaper for both the Attenuator filters and Pulse Picker, but implementing the controls side would be much more expensive, which is why steppers are being used. Lead screws ensure that system is not back-driveable and will hold the arms wherever they are when power is lost. Also, a power-off brake may be added.

Chamber assembly is designed to be installed with either end forward—including swapping the pulse picker.

The presentation included a modal analysis of selected components of both systems. It doesn't appear that the Attenuator/Pulse Picker system is particularly sensitive to vibration induced problems but if the goal is to make sure that all components meet a minimum criteria then further analysis or testing would be required. It appears that the primary contributors in this system would likely be the linear feedthroughs holding the filters and the pulse picker. Since there are several variables in the filter assembly, such as the feedthroughs being mounted in different orientations, some vertical, some at 45 degrees and some horizontal and all with varying masses cantilevered on the end. It could be possible that one of these assemblies could have a natural mode which is low enough to be problematic and could possibly excited by the 20 Hz cycling of the pulse picker. Because all the variables in a system like this, it is difficult to analyze them using FEA and some physical testing might be required. Since all problems are likely correctable this should still be a low risk item but should not be ignored.

Safety

Remember to include safety covers for the windows and a pressure relief valve for nitrogen backfill, and a burst disk if required.

Pulse Picker

The pulse picker flapper is controlled such that it is flipped in/out between pulses.

Seesaw flapper has iron, copper, and silicon-nitride brazed together. With the intermediate copper sheet, no dose gets to the iron, since it is attenuated in the silicon-nitride then fully absorbed by the copper. Copper is presumed to be needed to accommodate the difference in thermal expansion coefficient between the silicon-nitride and iron.

Shields prevent an off-center beam from hitting components of the shutter. This is needed since the shutter has such a small acceptance area.

The off-the-shelf flapper mechanism needs to be heavily modified to fit it into the assembly—brazing, cutting away parts of the support housing, re-aligning the shaft. However, the power supply and controls system that comes with this make it the lowest cost alternative.

Attenuator

Filters of any thickness can be installed in any port, although the plan is to put the thickest filter first. Filter assemblies will be labeled to ensure the right filter goes in the right slot, and filters can be inserted into the light beam one at a time while downstream diagnostics will be able to verify which thickness is in which location. Operational check-out of the attenuator will include verification of the photon attenuation for each thickness of silicon.

Max power deposited in a filter is 250 mW. This can be radiated with a 30 degC temp rise, which is acceptable. However, it is not clear if this will produce a bow in the filter. There is no spec on flatness or figure for the filters, so a slight bow is apparently not a problem.

The extremely thin silicon attenuators may be difficult to handle mechanically. It may be beneficial to acquire samples of the thinnest silicon material to test handling and assembly procedures.

Investigate using Belleville or wave washers, or other means to control the clamp load on the filters. Relieve the covers so they don't bear against the edges of the filters which would introduce local stress concentrations.