

ENGINEERING SPECIFICATION DOCUMENT (ESD)	Doc. No. SP-391-001-30 R1	LUSI SUB-SYSTEM XCS DIFFRACTOMETER
<h3>LUSI XCS Diffractometer System Engineering Specification Document</h3>		
Prepared by: Eric Bong XCS Lead Engineer/WBS Manager	_____	_____
	Signature	Date
Approved: Aymeric Robert XCS Instrument Scientist	_____	_____
	Signature	Date
Approved: Darren Marsh Quality Assurance Manager	_____	_____
	Signature	Date
Approved: Tom Fornek LUSI Project Manager	_____	_____
	Signature	Date

Revision	Date	Description of Changes	Approved
R0	27MAR09	Initial release	
R1	08MAY09	Changes requested after Procurement Review	

Table of Contents

1. Scope:	3
2. Glossary / Definitions:	3
3. Documents, Specifications and Codes:	3
3.1. SLAC Documents:	3
3.2. SLAC Specifications:	4
3.3. Industry Specifications and Codes:	4
4. Diffractometer System Summary:	4
5. Diffractometer System Use and Location:	4
6. Local Coordinate System and Interaction Point:	5
7. Diffractometer System:	6
7.1. Diffractometer Base [XX_air]:	7
7.2. Alignment of the rotation axis [XX]	8
7.3. Local Detector Rotation and Sub-motions $[2\theta, R, Y_d, \gamma]$	8
7.4. Rotation of the sample in the CoR $[\theta]$	9
7.5. Alignment of the CoR height [YY]	10
7.6. Tilt rotations $[\chi, \phi]$	10
7.7. Sample manipulation stage [X,Z,Y]	10
7.8. Diffractometer System Operational Requirements	11
7.8.1. Mean operational height for the CoR:	11
7.8.2. Dimension of the top platform:	11
7.8.3. CoR from top platform distance:	11
7.8.4. Maximum Load	11
7.8.5. Sphere of Confusion	11
7.8.6. Stability	12
7.8.7. Local Obstruction Avoidance	12
7.8.8. Base special features:	12
7.8.9. Seismic Consideration for the Diffractometer	12
7.8.10. Operational Hutch Environment.	13
8. Motion Control Requirement:	13
8.1. Motor Specifications and Requirements:	13
8.2. Encoder Specifications and Requirements:	13
8.3. Limit Switches:	13
9. Cable Management:	13
10. Power and Data Cable Requirements / Interface:	14
10.1. Power Cabling Requirement / Interface:	14
10.2. Control Cabling Requirement / Interface:	14
11. Reviews	14
12. Environmental Safety and Health Requirements	15
12.1. General Seismic Considerations	15
13. Supplemental System Requirements:	15
13.1. Materials	15
13.2. Paint Color	15
APPENDIX A : Revision 1: Primary Changes Affected Sections	17

1. Scope:

This document defines the engineering requirements for a Diffractometer System to precisely support, translate, and rotate samples in the LUSI X-ray Correlation Spectroscopy (XCS) instrument and position a local detector. The diffractometer system must have the ability to be removed from the beam path, thus leaving a clear floor print. This will allow accommodating very large sample environment which are not compatible with the diffractometer system design and ensures a very large flexibility of the XCS instrument.

The present diffractometer is a 4-circle nearly horizontal scattering geometry diffractometer.

2. Glossary / Definitions:

Accuracy: The absolute error in the ability to establish a specified location and angle with respect to the origin of a fixed coordinate system.

XCS Detector: Pixilated x-ray detector.

Detector Mover: Positions the local detector relative to the sample.

ESD: Engineering Specification Document

Experiment Sphere of Confusion: The Uncertainty in absolute location of the intersection of the x-ray beam, and the sample goniometer rotation center throughout the range of motion.

FEH: Far Experimental Hall

Goniometer: Precision positioning device which provides angular and spatial sample motion.

Mechanical Sphere of Confusion: Uncertainty in absolute position of the sample Goniometer center of rotation.

Pitch: Rotation about the X-axis (horizontal, normal to x-ray beam axis).

PRD: Physics Requirement Document.

Range: The total available motion with respect to a fixed coordinate system origin.

Repeatability: the absolute error in the ability to successively reestablish a specified location/angle, with respect to the origin of a fixed coordinate system.

Resolution: The uncertainty of the measurement of location/angle with respect to the origin of a fixed coordinate system.

Roll: Rotation about the Z-Axis (the x-ray beam axis)

Stability: The amplitude of motion over a specified time.

XRT: X-Ray Tunnel

Yaw: Rotation about the Y-axis (the vertical axis)

3. Documents, Specifications and Codes:

3.1. SLAC Documents:

GP- 391-750-60

MR-391-750-00

LO- 391-750-41

HUTCH4 LAOUT II ASSY

MASTER BEAM LINE

H4 XCS STAY-CLEARs

3.2. SLAC Specifications:

AP-391-000-59	Engineering Review Guidelines
DS-391-000-36	Design Standards Supplement
SLAC-I-720-0A24E-002	Specification for Seismic Design at the SLAC
SP-391-001-32	XCS Diffractometer System Physics Requirements
SP-391-001-35	XCS Instrument Physics Requirements
SP-391-001-29	XCS Instrument Engineering Specification

3.3. Industry Specifications and Codes:

NEC, NFPA 70:	National Electric Code
NEC, NFPA 70E:	Electrical safety in the Workplace
CBC 2007:	California Building Code, 2007

4. Diffractometer System Summary:

The XCS Diffractometer System is used to precisely control the location and orientation of samples/sample environments in the LCLS x-ray beam and to detect the direction of the scattered signal. It is comprised of a sample goniometer which positions the sample in position and rotation and a detector mover which positions a local detector. The diffractometer system must provide a stable and reproducible position and angular orientation of both the sample and local detector for the duration of an XCS experiment. The physics requirements of the Diffractometer System are described in SP-391-001-32, XCS Diffractometer System Physics Requirements.

5. Diffractometer System Use and Location:

The XCS diffractometer system is to be installed in the Hutch 4 of the Far Experimental Hall, as described in Fig 1.

The XCS instrument will be used to as a multipurpose instrument. Therefore the type of samples, sample environment and scattering geometry may change significantly from one experiment to another. Some experiment configurations may require the use of a specific sample environment which will require the complete removal of the XCS diffractometer system from the x-ray beam path. It is therefore required that the diffractometer system be air-pad mounted for quick removal and placement back on the beam-line. It is thus required that a clean smooth surface insert be installed in the floor, such as granite (or suitable alternative), for the diffractometer air-pads to be operational. The floor insert is to be included as part of the XCS diffractometer system (cf. Fig 1-2).

A system must be provided to establish the nominal position of the diffractometer system assembly at the XCS interaction point. The positioning system must re-index the diffractometer in the nominal interaction point when the diffractometer is moved off of and back onto the XCS beam-line. In addition, a second indexed position must be provided to position the diffractometer at an alternate interaction point position, 60 centimeters aside, parallel to the primary XCS interaction point (cf. Fig 2).

When not in use, the diffractometer system must be parked next to the South wall of the XCS hutch. The floor insert must extend towards the South wall a sufficient length to accommodate the movement of the diffractometer system to the “parked” position. In all three of the desired diffractometer positions; primary interaction point, secondary interaction point and park, the diffractometer system must be safely constrained against earthquake forces.

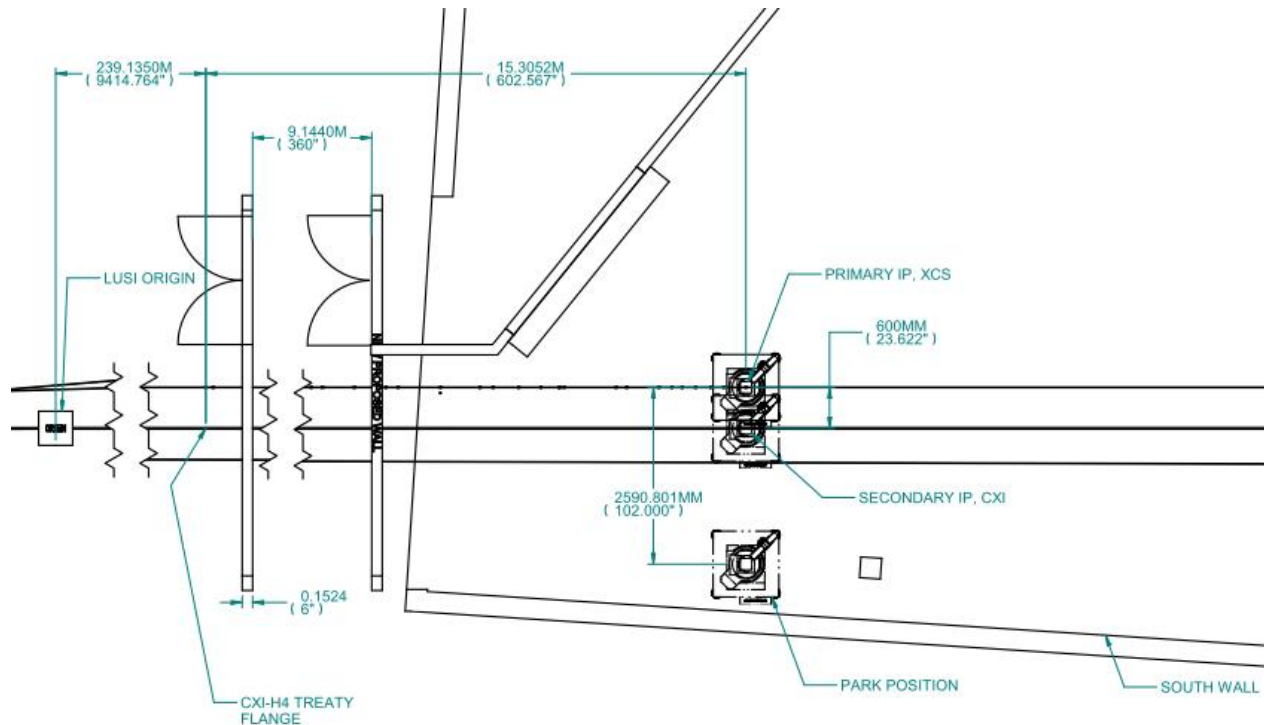

Figure 1
 Hutch 4 – XCS Instrument
 (XCS Hutch 4 Coordinate System referenced from GP-391-400-00)

6. Local Coordinate System and Interaction Point

The Hutch 4 local coordinate system as defined in DS-391-000-36 “Design Standards Supplement” and located in MR-391-750-00 “MASTER BEAM LINE”, is a right hand Cartesian system with Z+ axis in the direction of X-ray propagation, parallel to the floor, the X+ axis parallel to the floor and Y+ vertical up.

The diffractometer coordinate system is a right hand Cartesian with axes parallel to the Hutch 4 local coordinate system and origin at the center of the diffractometer sphere of confusion. During an experiment, the diffractometer coordinate system must be aligned with the interaction point of the x-ray beam and the sample, nominally 1.4 meters above the hutch floor. As described in SP-391-001-32, due to the requirements of specific experiments, the actual interaction point may vary as shown in Figure 2.

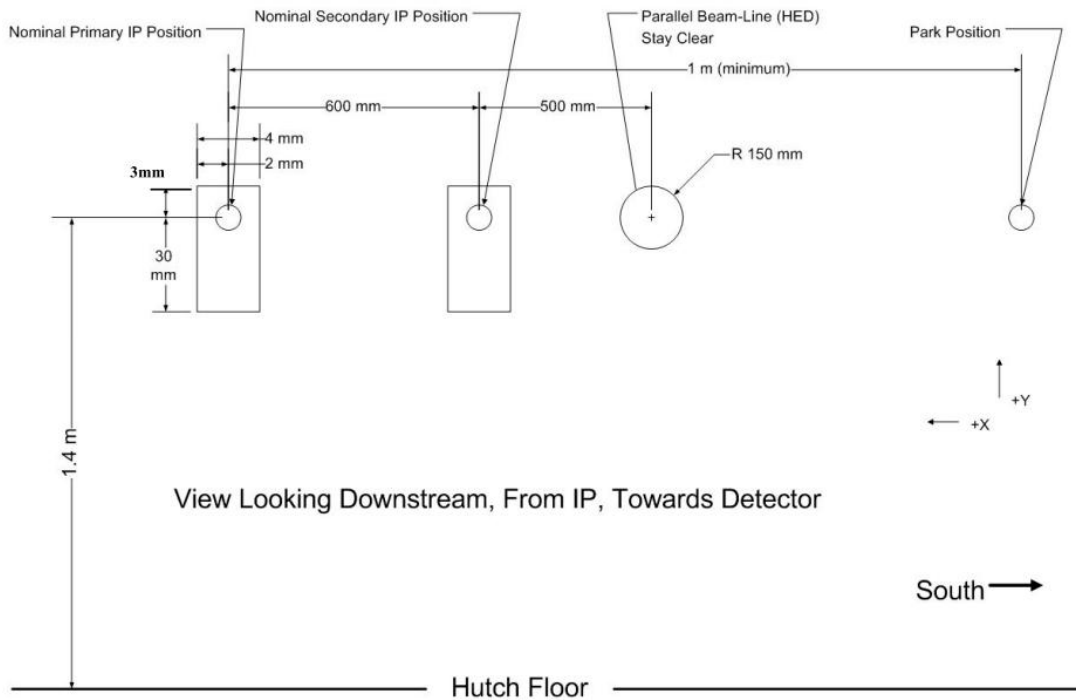

Figure 2
Interaction Points Range of Motion and description of the park position

7. Diffractometer System:

The diffractometer system is made up of a stack of components which provides the capability to locate a sample to the interaction point, position the sample in six degrees of freedom and orient a local detector about the interaction point.

The diffractometer system involves various translational and rotational degrees of freedom as described in Fig.3. A suggested vertical ordering of these various motions is presented in Fig. 3 in order to properly align the diffractometer system in the incident x-ray beam, but also in order to properly align and manipulate both the sample and the local detector. Proposed alternatives will be reviewed, provided the overall motions and specifications to operate the diffractometer are met.

All degrees of freedom require to be motorized, except for the solid granite base (or suitable alternative) on air-pads [XX_air], and the radial adjustment [R] of the local detector tower.

All the other motions must be motorized following the requirements described in Sec. 8.

The next sections describe in details the requirement in terms of range, repeatability, accuracy for each of the motions involved in the XCS Diffractometer System.

The general requirements applicable to the overall assembly are described in Sec. 7.8

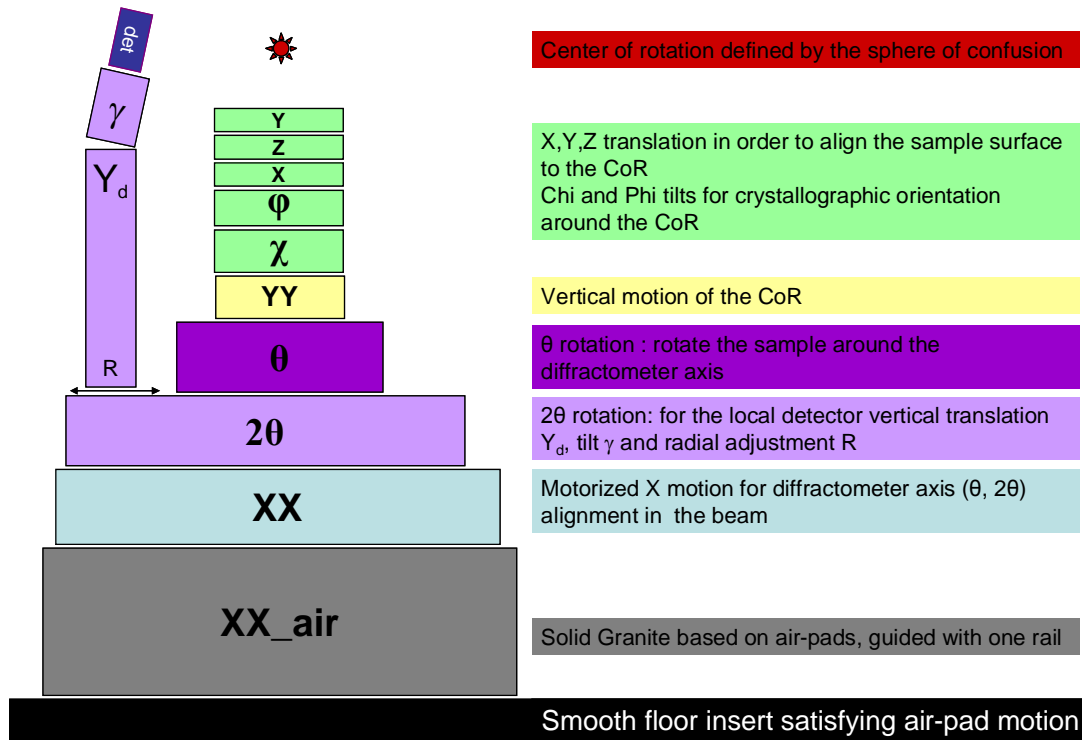

Figure 3
Schematic of the stack of required motions involved in the XCS Diffractometer System

7.1. Diffractometer Base [XX_air]:

The XCS Diffractometer must remain stable in a static position for the duration of an experiment. Occasionally, it must be moved to an alternate interaction point (located 600mm in the X direction), or to a park position adjacent to the South wall of the XCS Hutch. The floor space vacated by the XCS diffractometer must be clear of obstacles and irregularities to provide accommodation for alternative experimental equipment.

When the diffractometer is installed in either the primary interaction point position, the alternate interaction point position or in the park position, it must be restrained from earthquake induced motion (c.f. Sec. 7.8.9). The motion along the X-direction between the three operational positions should be accomplished by use of air-pads permanently installed under the mounting base. The air-pads should ride on a smooth floor insert embedded to the hutch floor. When placed at the primary or alternate IP positions, the diffractometer must return to an indexed position with the following requirements:

Direction	Repeatability
X,Z	+/- 0.5 mm

This can potentially be achieved with the help of guiding rail in the X-direction. **The [XX_air] motion is not motorized.**

Special care should be taken in the design phase to investigate the overall position stability, when placed in a fixed operating position, in order to make the device more robust to the floor vibration.

The surface flatness and roughness of the floor must be compatible with the use of the granite (or suitable alternative) base air pads and is considered part of the diffractometer system. The required surface condition may be accomplished by embedding a granite insert in the floor or by other means approved by The LUSI XCS responsible Physicist and Engineer.

7.2. Alignment of the rotation axis [XX]

The vertical rotation axis of the diffractometer is defined by the coincidence of the [2θ] and [θ] rotation axis. The two axes will be placed in coincidence at mounting.

The purpose of the motorized horizontal translation [XX], is to precisely align the diffractometer vertical rotation axis in the x-ray beam. This helps correct any repeatability issue as a result of the [XX air] air-pad motion of the overall assembly. It also allows the precise correction of any position deviation from the x-ray beam in the horizontal plane (i.e. deflection as a result of upstream optical components).

Direction	Range (mm)	Accuracy (micron)	Repeatability (micron)	Resolution (micron)	Stability (micron / hour)
XX	80 (+/-40)	5.0	1.0	<1.0	<1.0

7.3. Local Detector Rotation and Sub-motions [2θ, R, Y_d, γ]

The local detector consists in the present case of a pair of slits located in front of diode. It could potentially be substituted by another point-detector or eventually a small 2-dimensional detector. **The total weight of the local detector will be of the order of 10kg, maximum. The local detector is not part of the scope of the diffractometer system.**

The local detector global motion will have the possibility to describe a horizontally truncated sphere centered at the Center of Rotation of the diffractometer as described in Fig 4.

- The distance between the Center of Rotation of the diffractometer and the local detector should have a certain degree of tune-ability and **is not motorized**. This motion is described by the motion [R]. The motion is a radial motion from the axis of rotation of the diffractometer and can be achieved by a sliding rail.
- The CoR of the diffractometer has the possibility to translate vertically as a result of the upstream optical components as described in Fig.2. Therefore the local detector should have the same capability. This is provided by the vertical motion [Y_d].
- The rotation of the local detector is provided in the horizontal plane by the rotation [2θ]
- The rotation of the local detector in the vertical plane is provided (in the vicinity of the horizontal plane containing the CoR of the diffractometer) by [γ].
- A radius of rotation for the [γ] rotation larger than 200mm is required

- A proper interface piece should be provided in order to place the [Yd,γ] assembly and ensure that the center of rotation of the [γ] motion is located at average operational height (1400mm from the floor, c.f. Sec 7.8.1) when [Yd] is in the middle of its range.

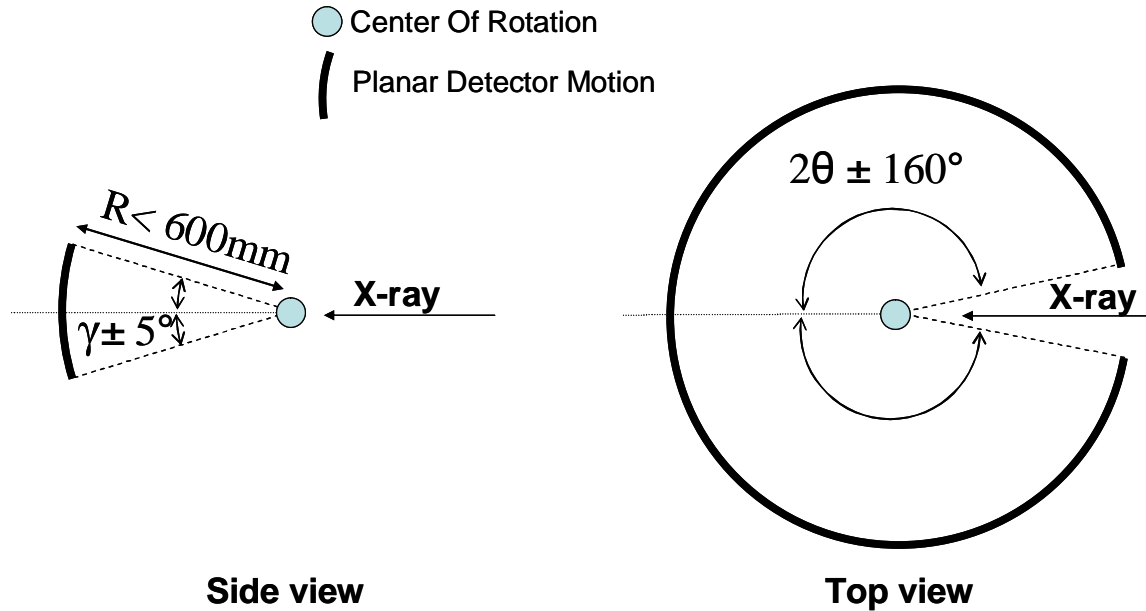

Figure 4: Local Detector Motion

Horizontally truncated sphere, centered at the center of rotation of the diffractometer.

Direction	range (mm)	accuracy (micron)	repeatability (micron)	resolution (micron)	Stability (micron / hour)
R	200 mm	n.a. (sliding rail. Not motorized)			
Yd	>200 mm	<6 (+/-3)	1.0 (+/-0.5)	<1.0 (+/-0.5)	<1.0
Direction	Range (degree)	Accuracy (arc-sec)	Repeatability (arc-sec)	Resolution (arc-sec)	Stability (arc-sec / hour)
2θ	320(+/-160)	<3.6	<1	<1	<6
γ	10(+/-5)	<3.6	<1	<1	<6

7.4. Rotation of the sample in the CoR [θ]

The rotation axis of the motorized [θ] rotation should be mounted in coincidence with the [2θ] rotation (located right below) in order to properly define the vertical rotation axis of the diffractometer. This motion allows precise rotation in the horizontal plane, of the sample in the CoR of the diffractometer

Direction	Range (degree)	Accuracy (arc-sec)	Repeatability (arc-sec)	Resolution (arc-sec)	Stability (arc-sec / hour)
θ (continuous)	360(+/-180)	<3.6	<1.0	<1.0	<6

7.5. Alignment of the CoR height [YY]

The purpose of the motorized vertical translation [YY], is to precisely align the height of the CoR of the diffractometer in the x-ray beam. The range of this translation should cover any change of the x-ray beam height as a result of the upstream optics. The nominal beam height is 1.4 meter from the ground. The range of motion is larger in the down direction than in the up direction. The straightness of this motion should be $\leq 20\mu\text{m}$.

Direction	Range (mm)	Accuracy (micron)	Repeatability (micron)	Resolution (micron)	Stability (micron / hour)
YY	$\geq 150(+50/-100)$	$\leq +/-3$	$\leq +/-2.0$	≤ 1.0	<1.0

7.6. Tilt rotations [χ, ϕ]

The purpose of the two partial rotations [χ, ϕ] is to precisely align the sample in the CoR of the diffractometer. These two motions [χ, ϕ] are 90 degrees crossed rotations over the X and Z axis respectively and have a limited range of motion. The two rotations [χ, ϕ] should however have a common CoR. This CoR should be mounted in coincidence with the vertical axis of the diffractometer defined by [$2\theta, \theta$].

The accuracy with which the various rotations [χ, ϕ, θ] can be placed in coincidence will define the Sphere of the Confusion of the diffractometer (described in Sec. 7.8.5).

Direction	Range (degree)	Accuracy (arc-sec)	Repeatability (arc-sec)	Resolution (arc-sec)	Stability (arc-sec / hour)
χ	>10 (+/-5)	<3.6	<3.0	<3.0	<6
ϕ	>10 (+/-5)	<3.6	<3.0	<3.0	<6

7.7. Sample manipulation stage [X,Z,Y]

The purpose of the three translation [X,Z,Y] is to precisely position the sample to the Center of Rotation of the diffractometer defined by the rotations [χ, ϕ, θ].

Direction	range (mm)	accuracy (micron)	repeatability (micron)	resolution (micron)	Stability (micron / hour)
X	≥20 mm (+/-10)	5.0(+/-2.5)	<1.0 (+/-0.5)	<1.0 (+/-0.5)	<1.0
Z	≥20 mm (+/-10)	5.0(+/-2.5)	<1.0 (+/-0.5)	<1.0 (+/-0.5)	<1.0
Y	≥20 mm (+/-10)	5.0(+/-2.5)	<1.0 (+/-0.5)	<1.0 (+/-0.5)	<1.0

7.8. Diffractometer System Operational Requirements

This section describes the operational requirements of the diffractometer system and is summarized below:

Mean operational height for the CoR	1400mm
Top platform dimension	≥ 250 x 250 mm ²
Distance Top Platform to CoR	>200 mm
Maximum load	50kg (110lbs)
Sphere of Confusion	<70 microns
Experimental Sphere of confusion	<100 microns

7.8.1. Mean operational height for the CoR

The mean operational height of the Center of Rotation of the diffractometer is 1400 mm from the floor. This correspond the nominal x-ray beam height, when considering that no optical element is modifying the beam height.

7.8.2. Dimension of the top platform

The top platform of the diffractometer system should be at least 250x250mm² in order to allow accommodating for a large variety of sample environments requiring a large mounting base. The use of interface plates (not part of the scope) will be in place for smaller sample environment mounting plates.

7.8.3. CoR from top platform distance

The center of rotation of the crossed tilt rotations should be located at least 200mm above the surface of the top vertical translation [Y] when that translation is at half its range of motion.

7.8.4. Maximum Load

The Sample Manipulation Stage shall accommodate a 110 lb (50 kg) payload with a center of mass up to 2 inch (~50 mm) above the goniometer center of rotation.

7.8.5. Sphere of Confusion

The Sphere of Confusion of the diffractometer should be better than 70 microns.

The experimental sphere of confusion (consisting of the sphere of confusion and the various degrees of freedom of the local detector $[\chi, \phi, \theta, 2\theta, \gamma]$) should not exceed 100 microns

7.8.6. Stability

The position of the sample shall not drift by more than 10 μm in X, Y, and Z, and not more than 0.3 mDeg (~ 1 arcsec) in roll, pitch, and yaw over 1 day. The CoR vibration shall be minimized to less than 1 μm . Vibrations shall not cause CoR angular deviations greater than 0.06mDeg (~ 0.2 arcsec).

7.8.7. Local Obstruction Avoidance

Specific care has to be taken regarding the interaction between the motion of the local detector and the possible nearby obstacles such as the CXI beam-line located 600mm south from the XCS beam-line and the HED beam-line located 500 mm South of the CXI beam-line. This could be performed by software (cf. Figure 2)

7.8.8. Base special features

The granite base (or suitable alternative) shall be provided with a pattern of threaded inserts embedded in all four sides. The inserts shall be $\frac{1}{4}$ -20 UNC female thread in a set of three 4 in by 4 in square bolt patterns as shown in the figure below. The minimum thread depth shall be 1 inch. The pattern must be centered on the surface.

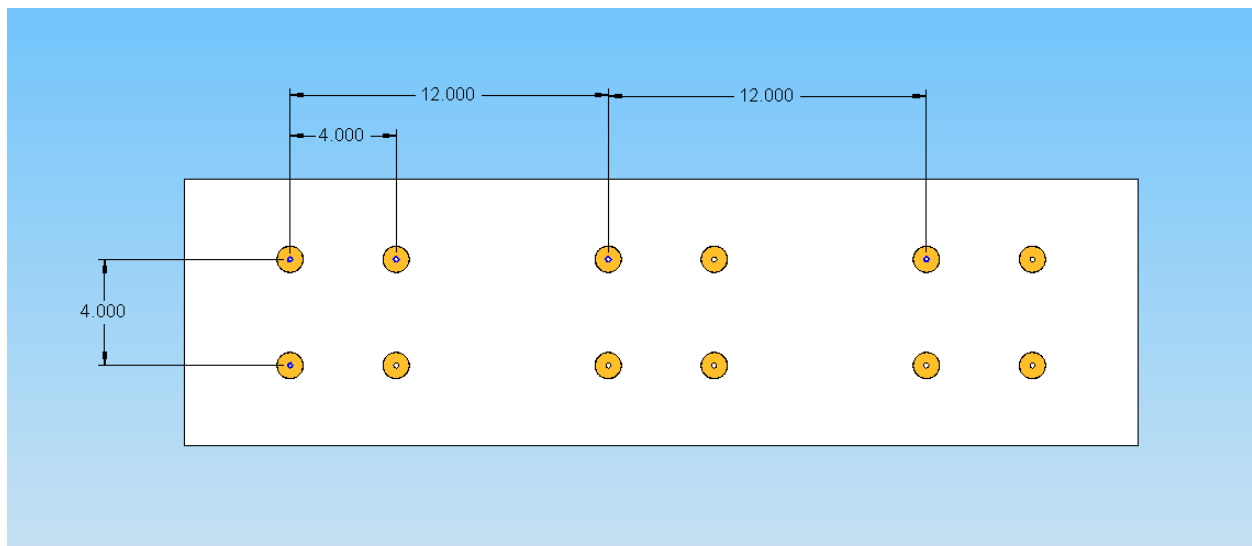

Figure 5: Base Insert Pattern

7.8.9. Seismic Consideration for the Diffractometer

SLAC is situated in an active seismic zone. All hardware exceeding a weight of 300 Lbs. and / or mounted greater than 4 feet above the floor will be reviewed by a SLAC “citizen safety committee” for

seismic loading resistance. Applicable loads and structural behavior will be evaluated for compliance to the 2007 version of the California building code and SLAC publication SLAC-I-720-0A24E-002: “Specification for Seismic Design of Buildings, Structures, Equipment, and Systems at the Stanford Linear Accelerator”.

7.8.10. Operational Hutch Environment.

The diffractometer will be operated in hutch 4 in the Far Experimental Hall. The experimental hutch is designed to provide temperature stability better than $\pm 1\text{F}$.

8. Motion Control Requirement:

As described in Sec. 7, every motion will be motorized except [XX_air] and [R]. A total of eleven motorized motions are required.

All translation and rotation elements shall be provided with adjustable hard stops where applicable. Rotation elements with motion range requirements of “continuous” are not required to have hard stops.

8.1. Motor Specifications and Requirements:

Motors shall be Intelligent Motion Systems, Inc. MDrive™ motion control version (MDI3CRL-XXX) “smart motors” using MDrive Plus™ and Expanded PLUS2™ Control.

8.2. Encoder Specifications and Requirements:

Translations and rotation axis requiring external encoding shall use hardware compatible with the requirements specified for closed loop-external connection for the Intelligent Motion Systems, Inc. MDrive™ motion control version (MDI3CRL-XXX) “smart motors” using MDrive Plus™ and Expanded PLUS2™ Control.

Translations and rotation axis not compatible with external encoding shall employ closed loop internal encoding specified for the Intelligent Motion Systems, Inc. MDrive™ motion control version (MDI3CRL-XXX) “smart motors” using MDrive Plus™ and Expanded PLUS2™ Control or open loop control.

8.3. Limit Switches:

All translation and rotation elements shall be provided with adjustable limit switches. Adjustability shall be provided such that the limit switch can be positioned to change state at the point of contact with the hard stop.

9. Cable Management:

All cabling shall be located, configured and labeled to provide rapid and intuitive reconfiguration of the Diffractometer system.

All power and data cabling shall be routed and strain relieved in a manner such that:

- 1) All translation directions and rotation axis can achieve full range capability, plus 10% of full range, without load on cable, connector or diffractometer hardware.
- 2) Rotation axis with a range specification of “360 degree continuous” shall be capable of plus/minus >180 degree of rotation, from nominal “zero” without load on cable, connector or diffractometer hardware.

The main trunk cable from the controls rack to the diffractometer system will terminate at the South face of the granite base. The terminations must be located on DIN rail mounted connector blocks. The trunk cable must be capable of being disconnected for storage of the diffractometer in the park position. The trunk cable must also accommodate connection to the diffractometer in both the primary and secondary IP locations. The main trunk cable must be capable of being stored out of the way of either IP when alternate experimental support structures are in use.

Each motor on the diffractometer must have an individual cable termination at a DIN rail block located on the SOUTH side of the granite base. Each cable termination must be a mil standard metal multi-pin twist-lock connector. Selection of connector types must be approved by LUSI Controls group.

10. Power and Data Cable Requirements / Interface:**10.1. Power Cabling Requirement / Interface:**

Power cable gauge size shall be the maximum size applicable to the given motor frame. Power cabling shall be of sufficient length to terminate at DIN block.

10.2. Control Cabling Requirement / Interface:

Control cabling shall be consistent with the requirements and specifications of Intelligent Motion Systems, Inc. MDrive™ motion control version (MDI3CRL-XXX) “smart motors” using MDrive Plus™ and Expanded PLUS2™ Control.

Motor controller to serial port server shall use RS-422/485 protocol. Communications port connector at motor shall be 10-pin friction lock wire crimp (style RL)

All control communications cabling shall be of sufficient length to terminate at DIN blocks.

11. Reviews

All systems hardware will be subject to SLAC review and approval. Reviews will be conducted in accordance with SLAC document number AP-391-000-59: “Engineering Review Guidelines”. SLAC reserves to right to employ an internal (SLAC direct), external-independent, or mixed source review panel.

Particular review attention will be devoted to:

- Personnel access restriction methodology
- Emergency stop methodology / mechanisms
- Power failure provision – fault modes
- Electrical Safety including Lock-Out / Tag-Out
- Training mode functionality
- Maintenance mode functionality.

All electrical hardware must meet SLAC electrical safety standards.

12. Environmental Safety and Health Requirements

12.1. General Seismic Considerations

SLAC is situated in an active seismic zone. All hardware exceeding a weight of 300 Lbs. and / or mounted greater than 4 feet above the floor will be reviewed by a SLAC “citizen safety committee” for seismic loading resistance. Applicable loads and structural behavior will be evaluated for compliance to the 1997 version of the uniform building code and SLAC publication SLAC-I-720-0A24E-002: “Specification for Seismic Design of Buildings, Structures, Equipment, and Systems at the Stanford Linear Accelerator”.

13. Supplemental System Requirements:

Requirements, including the following topics, will be addressed in detail in subsequent procurement specifications and contracts.

- i. Inspection, testing and acceptance
- ii. Installation support services
- iii. Training support services
- iv. Maintenance procedures, schedules and assistance
- v. Repair and overhaul services

13.1. Materials

All parts and materials for the device shall be new and compatible with the performance requirements of this specification. No part interfaces should result in galvanic corrosion for the life of the system.

No system, sub-system or part shall be reconditioned or remanufactured.

All applicable material safety data sheets (MSDS) shall be provided and stored in an accessible location.

13.2. Paint Color

All painted surfaces are to be painted purple, defined as federal standard 17100.

APPENDIX A : Revision 1: Primary Changes Affected Sections

These changes are the result of the outcome of the XCS Advanced Procurement Review, held on April 23, 2009.

- Sec. 5 : “granite” has been replace by “granite (or suitable alternative)”
- Figure 2 : The figure has been updated to reflect the proper vertical range over which the incident beam may be located (updated from 2mm to 3 mm). It is now consistent with the other ESD’s.
- Sec. 7. Introduction : “ The vertical ordering of these various motions is required” is now replaced by : “ A suggested vertical ordering of these various motions is presented in Fig.3 ...detector. Proposed alternatives will be reviewed, provided the overall motions and specifications to operate the diffractometer are meet.”
- Sec. 7. Introduction : “ granite base” is replaced by “ granite base (or suitable alternative)”
- Sec. 7.1 : adding : “Special care should be taken in the design phase to investigate the overall position stability, when place in a fixed operating position, in order to make the device more robust to the floor vibration.”
- Sec. 7.5 : Add “ The straightness of this motion should be $\leq 20\mu\text{m}$.”
- Sec. 7.8.2 : typo corrected “ bet” replaced by “be”.
- Sec. 7.8.8 : Remove Granite from the title and extend any “granite” to “granite (or suitable alternative)”.
- Add a section 7.8.10 regarding the operational hutch environment
-