



LCLS Interface Control Document	1.1-523 X-Ray Endstation Systems	Revision 0
XES to LUSI ICD		
Stefan Moeller Author, Manager, X-Ray Endstations	 Signature	4/25/08 Date
Gunther Haller Author, Manager, Photon Systems Controls	 Signature	5-2-08 Date
David Fritz Author, LUSI Scientist	 Signature	4/30/08 Date
Sebastien Boutet LUSI Scientist	 Signature	05/01/08 Date
John Arthur Photon Systems Manager	 Signature	4-29-08 Date
Bill White Manager, Laser Group	 Signature	4/29/08 Date
Tom Fornek Manager, LUSI	 Signature	4/29/2008 Date
Darren Marsh Manager, Quality Assurance	 Signature	4/30/08 Date
John Galayda Director, LCLS Construction	 Signature	5/2/08 Date

Brief Summary:

This document describes the interface between the X-Ray Endstation Systems (XES) and the LCLS Ultra-fast Science Instruments (LUSI).

Change History Log

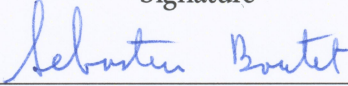
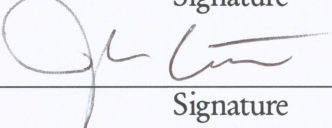
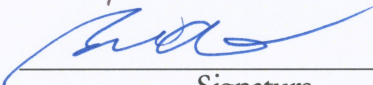
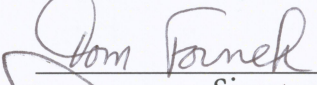
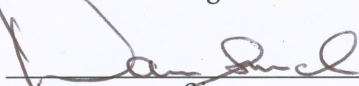
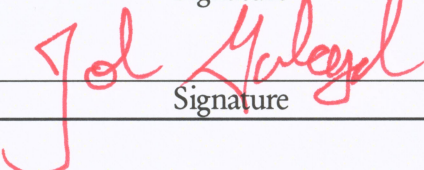
Rev Number	Revision Date	Sections Affected	Description of Change
000	4/22/08	All	Initial Version

EXECUTIVE SUMMARY

1.1 Scope: The purpose of this document is to define the interfaces and responsibilities between the X-Ray End Station (XES) and the LUSI project. Interfaces occur in four technical systems: the control system, the laser system, the vacuum (PPS stoppers) system, and the detector system for CXI. Geographically these interfaces are located: for the Controls in the NEH, the x-ray tunnel and FEH; for the laser systems in NEH, for PPS stoppers in hutch 3 and in the x-ray tunnel; for the detector in hutch 5.

1.2 Responsibilities

WBS	Represented by	Responsible for:
LUSI	<i>Tom Fornek</i>	Supporting, maintaining, and approving this ICD
1.6	<i>Stefan Moeller</i>	Preparing, maintaining, and approving this ICD

1.3 Interface Diagram

See below diagrams for CXI instrument and stopper locations.

4.0 Interface Description

Heading	Check	Type	Location and Description
4.1	X	Mechanical	Possible interference of stopper tank with XPP beamline in hutch 3 NEH
4.2	x	Fluid	Gas or fluid for cooling of the Cornell detector
4.3	X	Vacuum	Interconnected at Conflat-type flanges at stopper tanks in hutch 3 and X-ray tunnel
4.4		Thermal	
4.5		RF	
4.6		Electrical	
4.7		Power	
4.8	X	Signal	Controls hardware and functionality for MPS, data and machine timing
4.9	X	Radiation	X-Rays and laser beam
4.10		Environmental	
4.11		Conventional Facilities	
4.12		Other	

2.0 Applicable Documents

PRD #1.6-005-r1 *Physics Requirements for LCLS/NEH Laser Safety Systems*
ESD # 1.6-115-r0 *Engineering Specification for the LCLS/NEH Laser Transport Controls*
PRD # 1.6-010-r0 *Physics Requirements for LCLS/NEH Laser System*
ICD # 1.1-517-r0 *XES Photon Controls to Electron Beam Controls Machine Protection System*
ESD # 1.6-113-r0 *LCLS Photon Stopper*
PRD # 1.6-002 *2D Detector Physics Requirements*

3.0 Interface Definition

Interfaces between the LUSI Project and LCLS XES occur along the controls, the laser, the Cornell detector and PPS stoppers systems. The interfaces for the controls and the laser systems are described in terms deliverables and responsibility. The interface for the Cornell detector and the PPS stoppers are defined in terms of location of the actual mechanical interface.

3.1 Controls

The Controls interface is between the x-ray Endstations (XES) Controls and Data Systems and the LUSI Controls & Data Systems. LUSI has experiments or components in hutch 3 in the Near Experimental Hall (NEH), the X-Ray Tunnel (XRT) and hutches 4 and 5 in the Far Experimental Hall (FEH).

There are certain areas where XES will provide control and data system components for all hutches and the XRT. Examples are PPS, Laser Safety System, User Safeguards, Laser Timing System.

The following areas have deliverables and/or have interfaces between the two systems.

- Machine Protection Systems (MPS)
- EPICS and Data Network
- Data Processing and Local-Storage
- 120-Hz-Beamline Data Network
- Accelerator Timing System

The following systems are completely provided by XES and are not further discussed in this document

- PPS
- Laser Systems Safety

- User Safeguards
- Laser Control System
- NEH server racks
- NEH fiber trunks
- Fiber trunk between NEH and FEH including terminations

The following systems are completely provided by LUSI and are not further discussed in this document

- NEH racks for hutch 3
- FEH racks for hutch 4, hutch 5, and the common server racks
- XRT racks for LUSI instruments
- AC power and water cooling to above racks
- FEH fiber trunks including terminations

3.1.1 Machine Protection System (MPS)

There will be between 1 and 4 (tbd) LCLS-standard MPS link-node boxes provided by XES in the photon area. In the current baseline are two MPS link-node in NEH, and one in FEH. Architecture is that the MPS link nodes receive open/close contact signals from LUSI beamline controls.

XES deliverables and services:

- MPS link-nodes and associated switches and terminal servers for NEH
- 48-pair electrical cable from each NEH hutch to the MPS link-nodes
- DIN-Rails in each NEH hutch providing up to 48 MPS link-node inputs each
- All cables and components upstream of MPS link-nodes (i.e. from link-nodes to MCC)
- Programming of MPS system.

LUSI deliverables and services:

- MPS link-nodes and associated switches and terminal servers for FEH and XRT
- All cables and hardware downstream of provided DIN-rails in each LUSI hutch and XRT (e.g. interconnections to open/close contacts of MPS actuators).

ICD # 1.1-517-r0 *XES Photon Controls to Electron Beam Controls Machine Protection System*

describes the details of the inputs signals into the MPS system and the required logic. LUSI signal definitions will have to be provided to XES when they are determined. XES will have them included in above document.

3.1.2 EPICS and Data Network

There is one EPICS server in NEH serving the NEH hutches, and one in FEH (tbd) serving the FEH hutches and XRT.

There are data switches in the NEH server room, the FEH server rack, the XRT, and in each hutch.

XES deliverables and services:

- EPICS server hardware for NEH
- NEH and FEH EPICS server configuration
- Create and maintain SLAC-standard EPICS installation
- NEH server room switches
- Configuration of all network switches
- Fiber connection from NEH server room switch to hutch switches

LUSI deliverables and services:

- EPICS server hardware for FEH.
- Connection from FEH EPICS server to network switches.
- FEH server rack switch
- Switches in each LUSI hutch.
- Fiber connection within FEH to FEH hutches and XRT.

3.1.3 Data Processing and Local Storage

There is one data-processing farm in the NEH server room, and one in the FEH processing rack. There is also one local storage system for NEH and one for FEH.

XES deliverables and services:

- Data processing farm and local storage for NEH
- Movement of data from NEH and FEH local storage to SCCS

LUSI deliverables and services:

- Data processing farm and local storage for FEH.

3.1.4 120-Hz Beam-Line Data (BLD)

The so-called beam quality data is used to screen experimental data. The beam quality data should be delivered to experimental hutch pulse-by-pulse reliably at up to 120Hz (synchronized with machine rep rate). At this time a dedicated 1G-Ethernet based solution is the baseline transport method.

XES deliverables and services

- Switch in NEH.
- Fiber connection from NEH to each NEH hutch
- Configuration of all switches

LUSI deliverables and services:

- Switch in FEH
- Fiber connection from the FEH switch to LUSI instruments.

3.1.5 Machine Timing

The XES system receives timing information from the electron-beam section of the machine. There is a fan-out in the NEH server room which distributes the timing information to each NEH and FEH hutch, and to XRT. Note that this is the accelerator timing system and not the LBL fast laser timing system.

XES deliverables and services:

- Upstream cables and components of timing system including fan-out modules in the NEH server room.
- Timing fibers to NEH hutch 3.
- Timing fibers from NEH to FEH.

LUSI deliverables and services:

- All timing hardware and cables in FEH and XRT for LUSI instruments
- Timing hardware and cables within NEH hutch 3.

3.2 Laser System

The interface for the Laser System refers to the laser and transport and laser controls and occurs in the Near Experimental Hall (NEH). This interface pertains to the common NEH laser system area and shared components.

XES is responsible for the Laser Hall optical table system - including the tables, legs,

enclosure, earthquake restraints and earthquake approval. XES is responsible for the Laser Safety System (LSS) for the Laser Hall, NEH Hutch 2 and NEH Hutch 3. The LSS includes shutters, doors, interlocks, LSS reviews and Personal Protection Equipment (PPE). XES will provide a stabilized beam delivery system into NEH Hutch 3.

LUSI will provide the NEH Hutch 3 optical table system. This includes the LSS interlocked laser enclosure. LUSI will provide the vacuum pump, pressure gauge, and controls for the Hutch 3 beam delivery system.

XES controls is responsible for the Laser Hall cabling and racks. This includes distributing power to the racks. XES controls is responsible for distributing timing signals to and within the NEH Laser Hall. The timing signals include the stabilized fiber RF timing as well as the beam rate Event Receivers (EVR).

3.3 Cornell Detector

The Cornell detector with the detector chip, electronics and the housing will be mounted inside the detector chamber of the CXI instrument. The interface is defined by the mounting area of the detector backside (provided by XES) and the translational stage faceplate (provided by LUSI). A signal cable and cooling lines for gas or water will connect to the detector (type and actual location of connectors to be specified). The connectors for cooling and signal are provided by XES. LUSI will provide everything up to the connector.

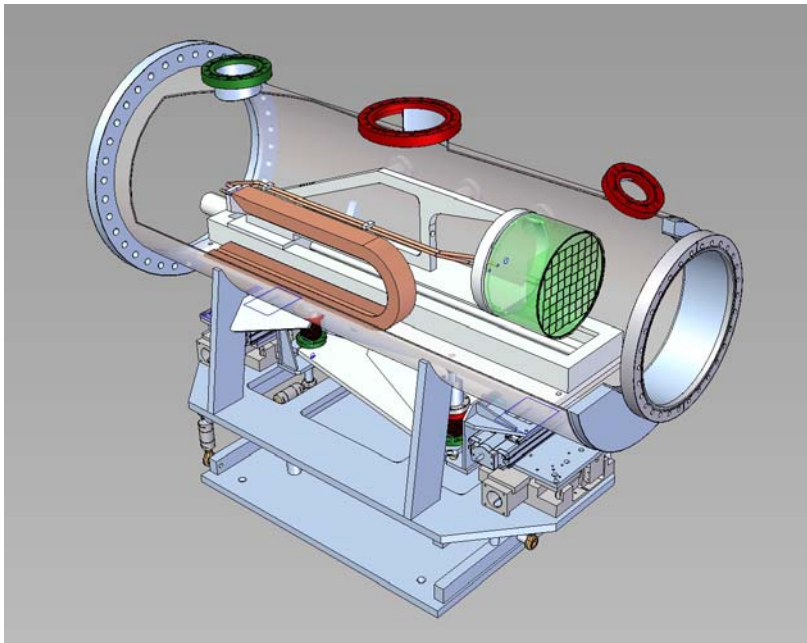

Figure 1: CXI detector chamber. The Cornell detector (shown in green) is mounted on a stage inside the chamber.

3.4 PPS Stopper Tank Interfaces with LUSI beamlines

XES provides the PPS Stopper hardware in the photon areas. The particular mechanical and vacuum interfaces with LUSI occur at two locations of the hard x-ray beamline. In hutch 3 of the NEH for stopper S3 in the XPP branch line. The interface occurs here at the flanges of the stopper tank (provided by XES) to the flange of the XPP beamline branch (provided by LUSI). It should be note here that the stopper tank design has been finalize so that the offset distance of the beamline needs to be consistent with the stopper tank dimension to avoid mechanical interference.

The second interface occurs at stopper 4 at the end of the x-ray tunnel in the XCS beamline. The interface runs along the connector flanges on either side of the stopper tank. The stopper tank drawings have been released and are available.

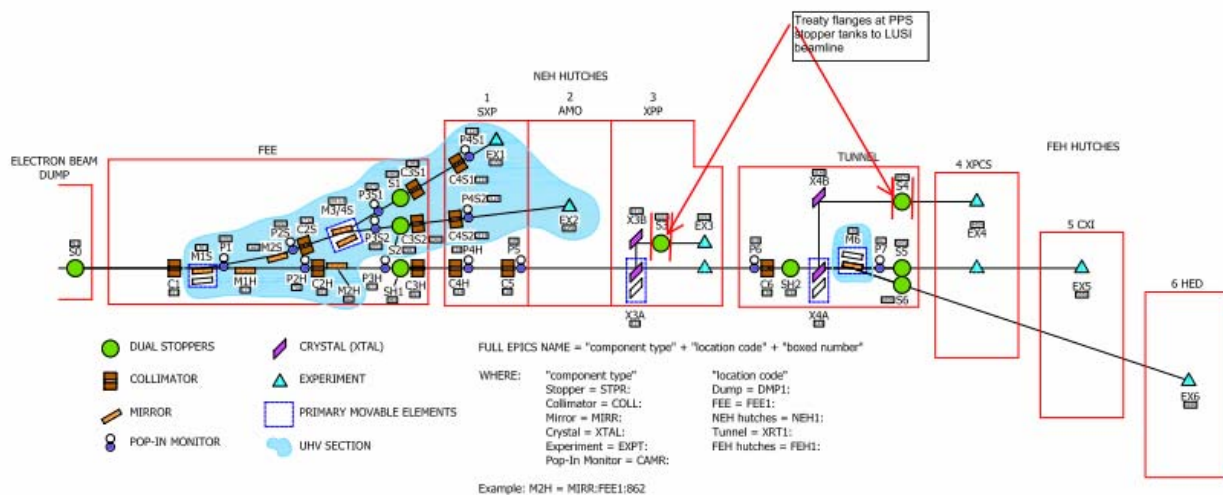

Figure 2: The arrows indicate the locations of the stoppers S3 in hutch 3 of the NEH and stopper S4 in the XRT in the XCS beamline. Interfaces to the other stoppers (S5, S6, SH2) are not interfaces with LUSI and are defined elsewhere.

4.0 Interface Requirements

4.1 Mechanical Requirements – Interference between LUSI and XES components should be avoided through mutual negotiation.

4.2 Fluid Requirements – The Cornell Detector requires gas or fluid for cooling of its electronics. Type of cooling substance need to be specified and types and location of connectors defined in a future ESD.

4.3 Vacuum Requirements – The LUSI Project agrees to adopt the specifications governing LCLS/XES vacuum systems, namely ESD #1.1-302 *LCLS Mechanical Vacuum Specification*. The stopper vacuum requirements are stated in ESD # 1.6-113-r0 *LCLS Photon Stopper*.

Vacuum requirements of the Cornell detector are specified in the PRD # 1.6-002 *2D Detector Physics Requirements*.

4.4 Thermal Requirements – None.

4.5 RF Requirements – None.

4.6 Electrical Requirements – None.

4.7 Power Requirements – None.

4.8 Signal Requirements – Functioning XES controls and laser controls require that all signals crossing the interfaces need to be specified and integrated. XES Controls and the LUSI project agree to establish compatibility in following a integrated documentation and design review process.

4.9 Radiation Requirements – The LCLS hard x-ray beam will be transported through the combined vacuum system, either to experiments performed in NEH Hutch 3, or/and experimental stations downstream. The laser beam will be delivered from the Laser Hall into hutch 3. Laser safety and beam stability requirements will be followed.

4.10 Environmental Requirements – None.

4.11 Conventional Facilities Requirements – None.

4.12 Other Requirements – None.

5.0 Verification – Verification of all requirements is to be performed during system commissioning. Performance goals for each system to be tested are described in the respective Physics Requirements Documents.

6.0 Notes –None.