

Measuring Saturation at **VISA-FEL**

A. Murokh

- Review of the diagnostics
- Discussion of the experimental results
- Near-term plans

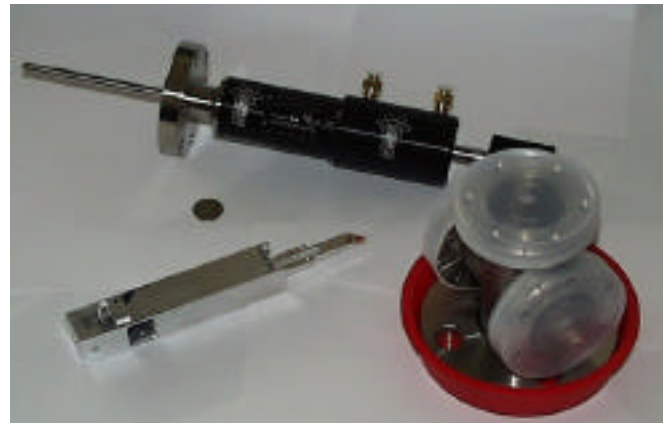

Diagnostics Overview

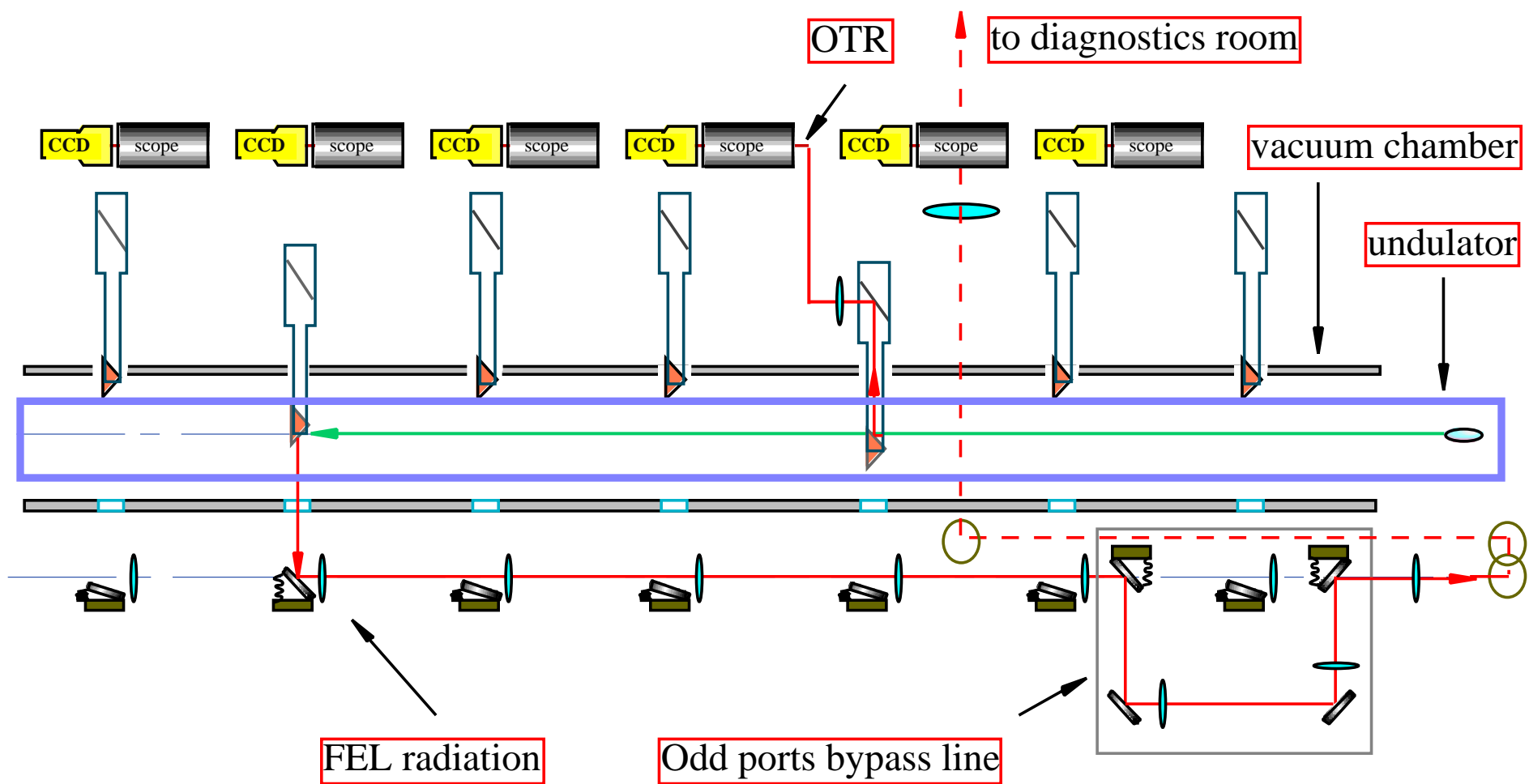

Undulator Probes

- There are 8 diagnostic ports 50 cm apart.
- A probe can be actuated in two positions: as BPM, and as FEL radiation diagnostic.
- The probe tips are made 2.3 mm thick, to clear the undulator gap opening.

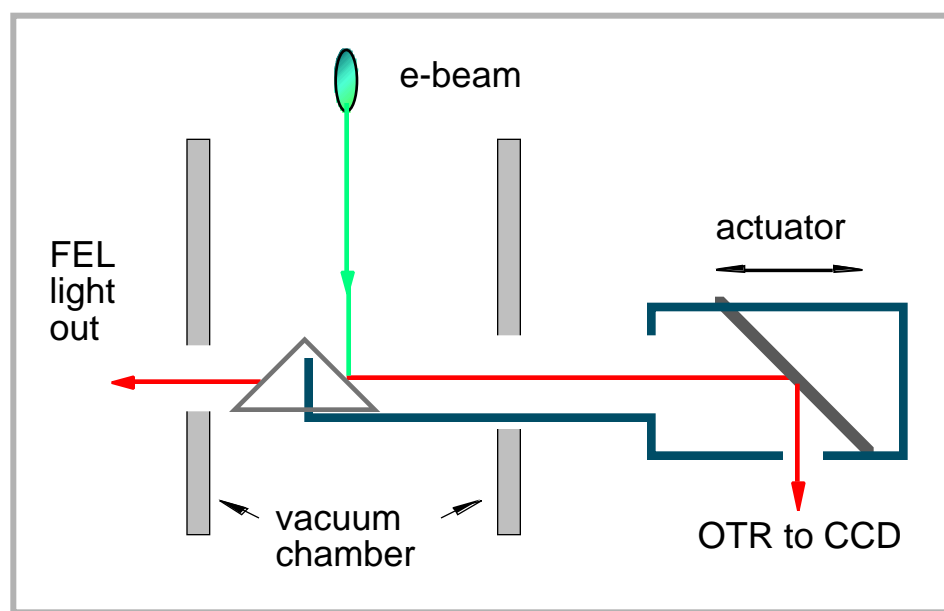
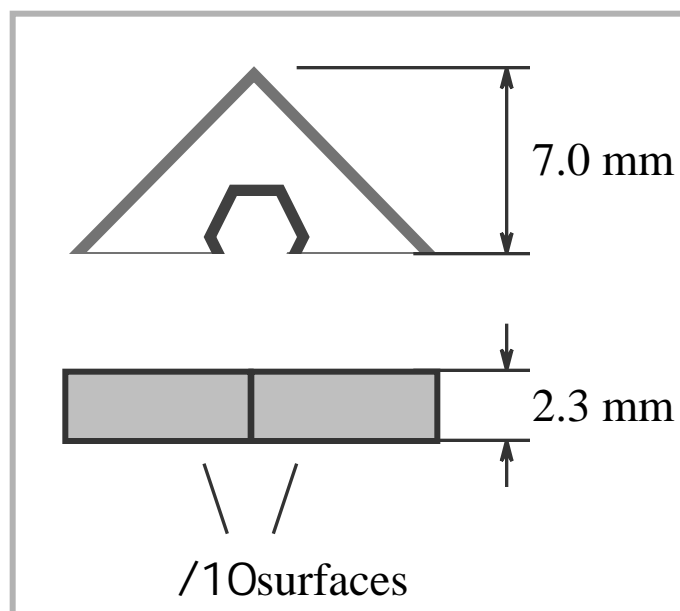

Choice of the Diagnostics

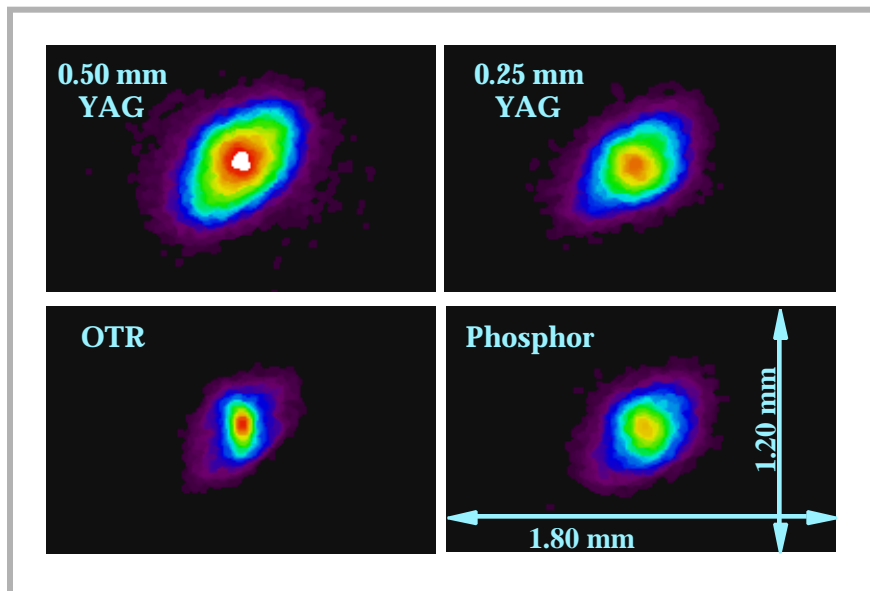

Scintillators do not generate an adequate electron beam image for small bright beams.

OTR is a low intensity signal, which is hard to separate from the undulator spontaneous emission

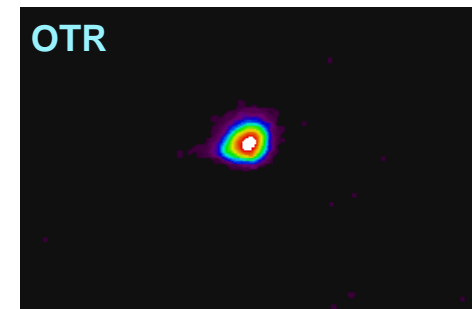
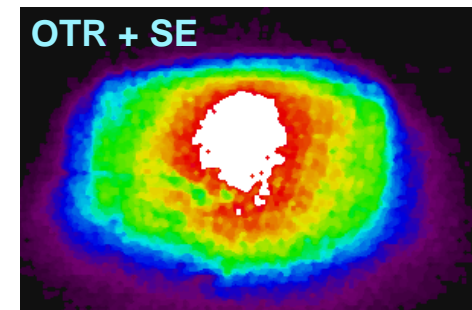

BPM Set-up

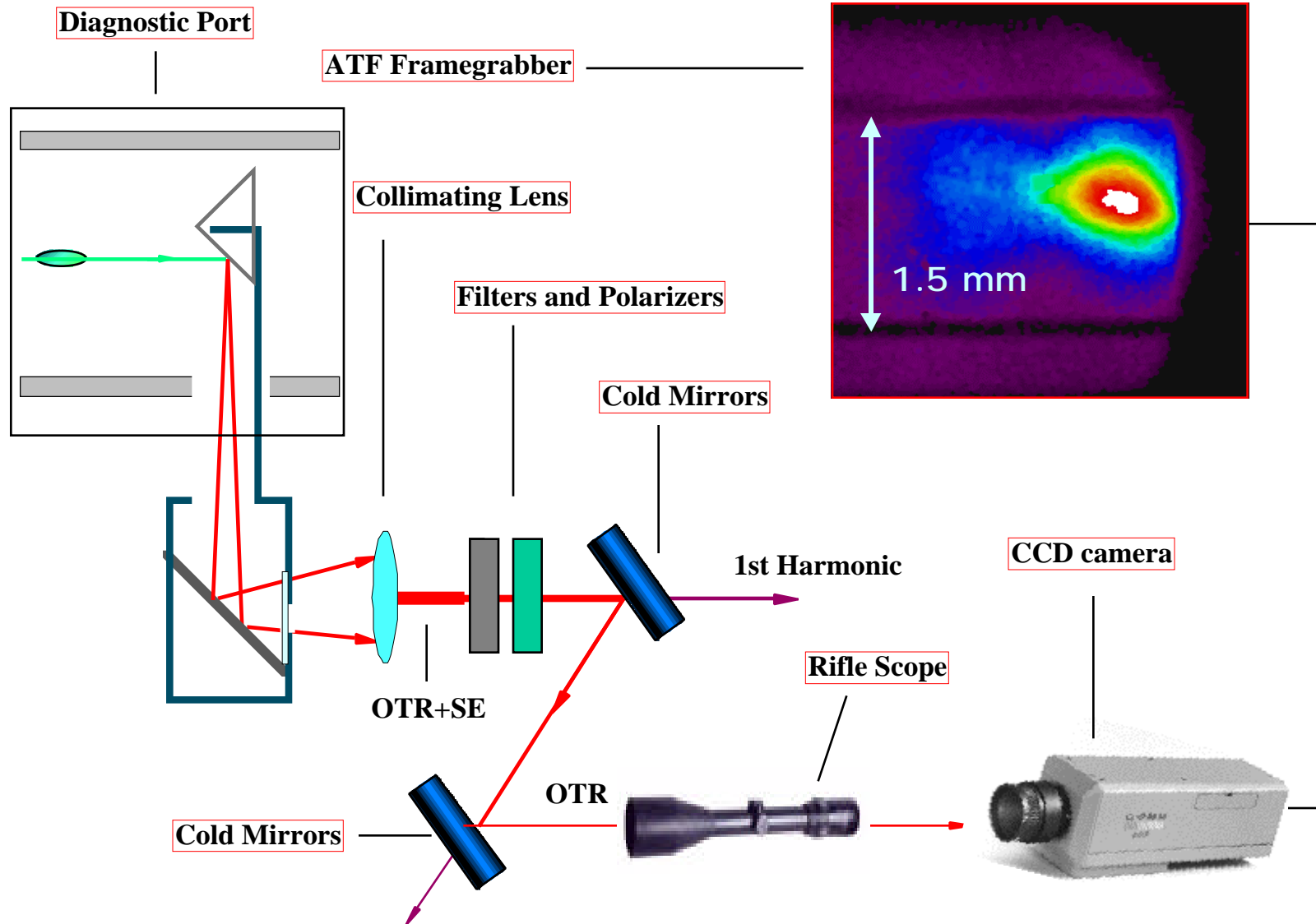

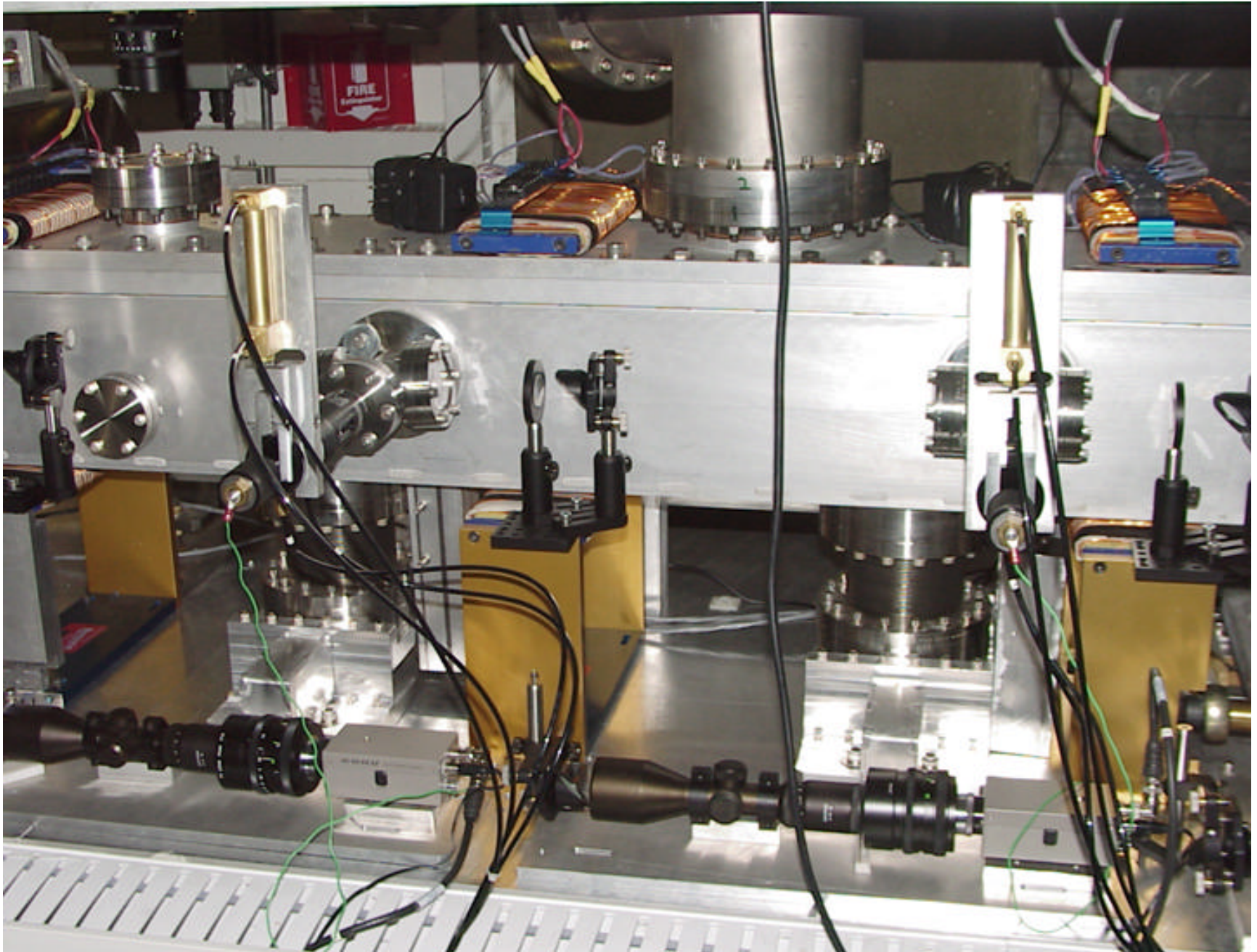

Overview of BPM Operation

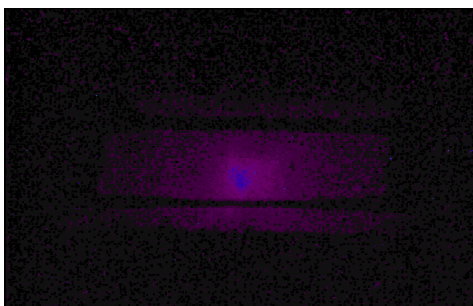

After noise reduction, image brightness is not sufficient for a careful envelope measurement

Trajectory measurements were successful, for large offsets. For small walk-off ($\sim 100 \mu\text{m}$) the measurements are limited by the system fluctuations.

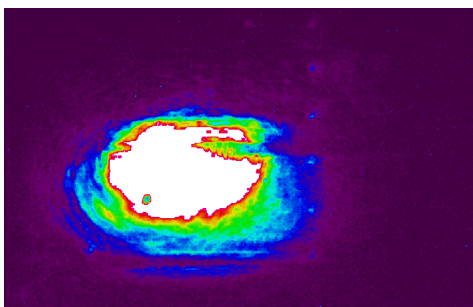
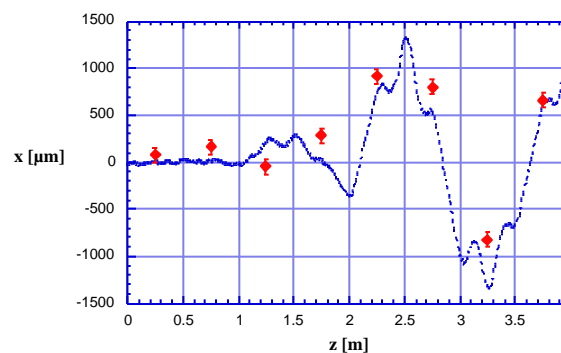

Unexpected BPMs' application came around with the high gain. We use last two BPMs to optimize the system performance.

Alignment Laser System

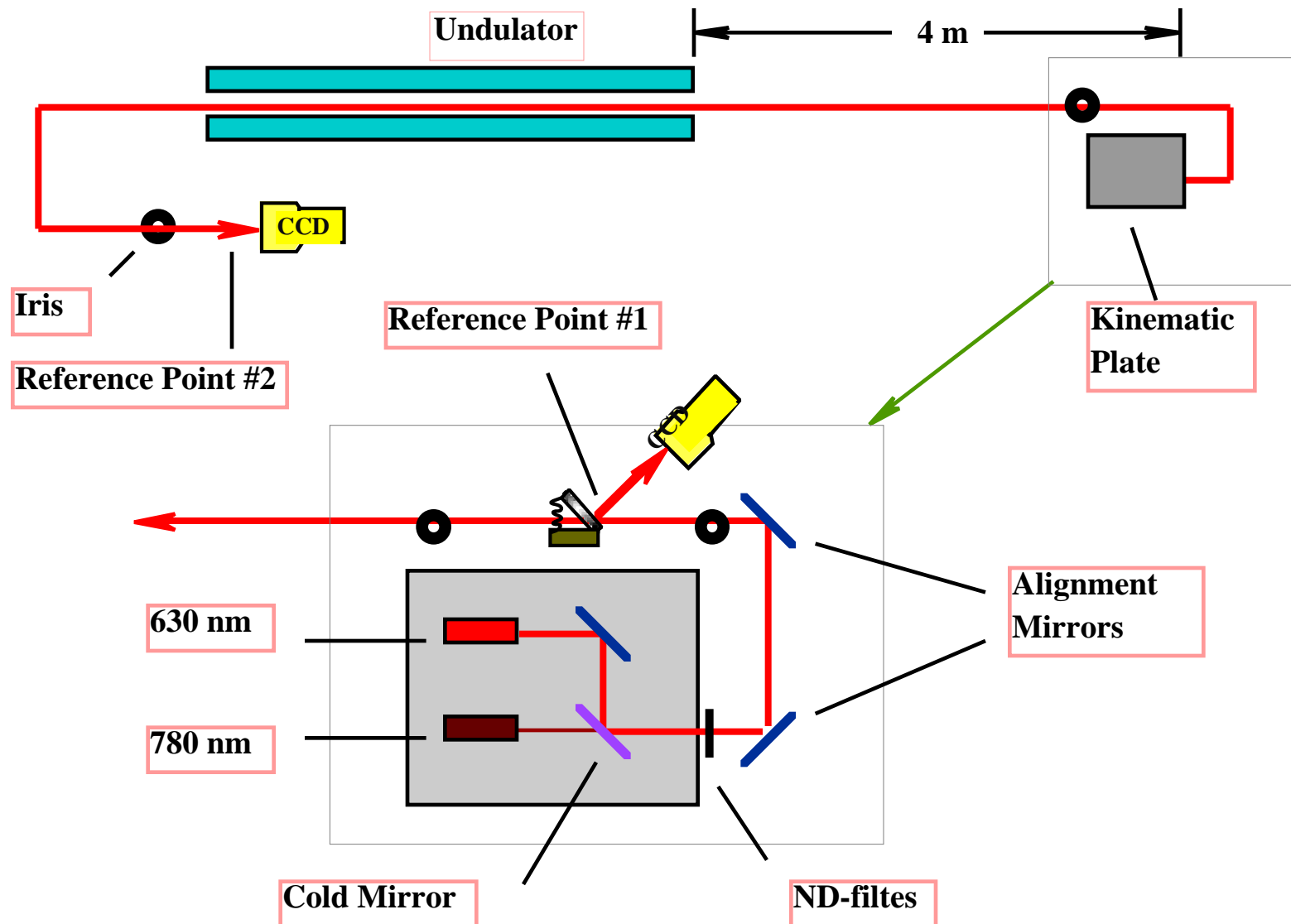

Laser Operation

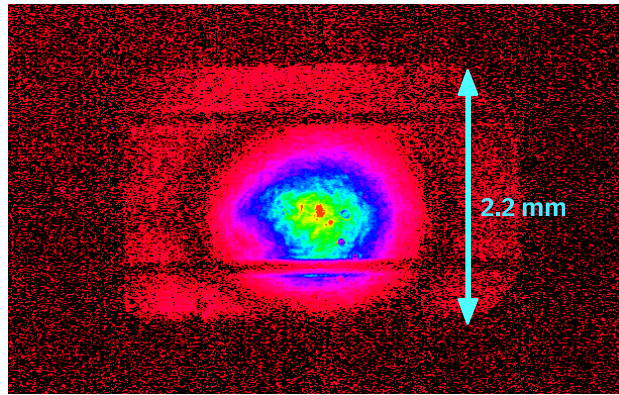

$$w = w_0 \sqrt{1 + \frac{z^2}{w_0^2}} \quad w_{\min} = \sqrt{\frac{L_u}{\dots}}$$

Laser spot jitter becomes stable in 5-10 minutes after the start up, and then stays within 20 μm :

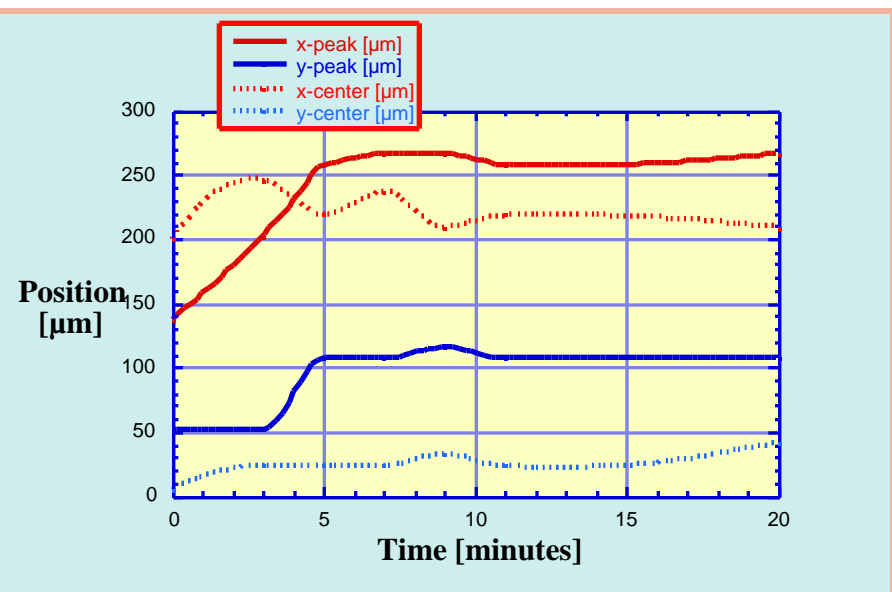

Imaging and Diagnostics

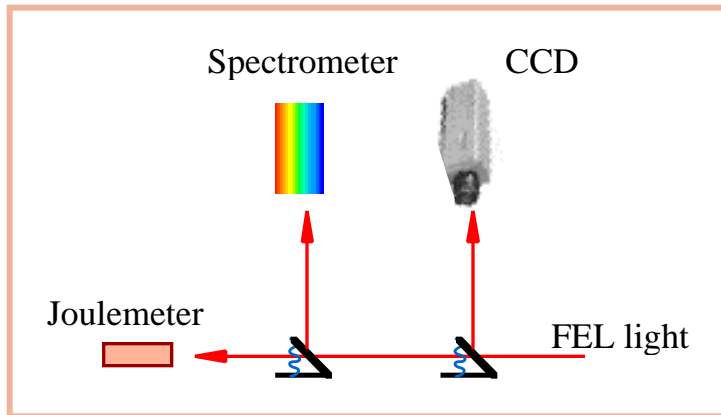

At the far end we can switch between joulemeter, spectrometer and CCD camera.

To multiplex between the ports relay imaging system is used.

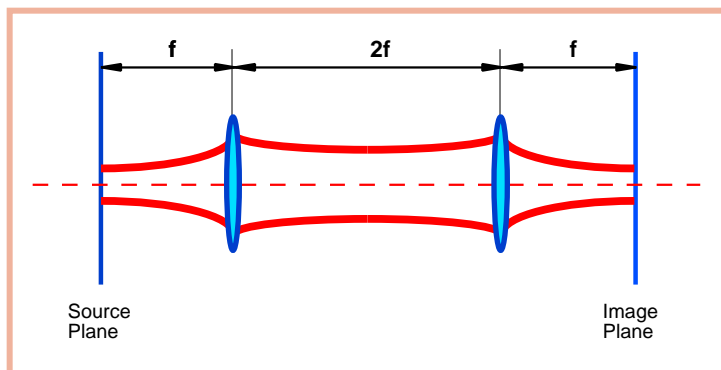

There is a large discrepancy between the ports in the angle (position) of injection into the imaging array. To improve the system, second mirror should be added to each port.



First Results

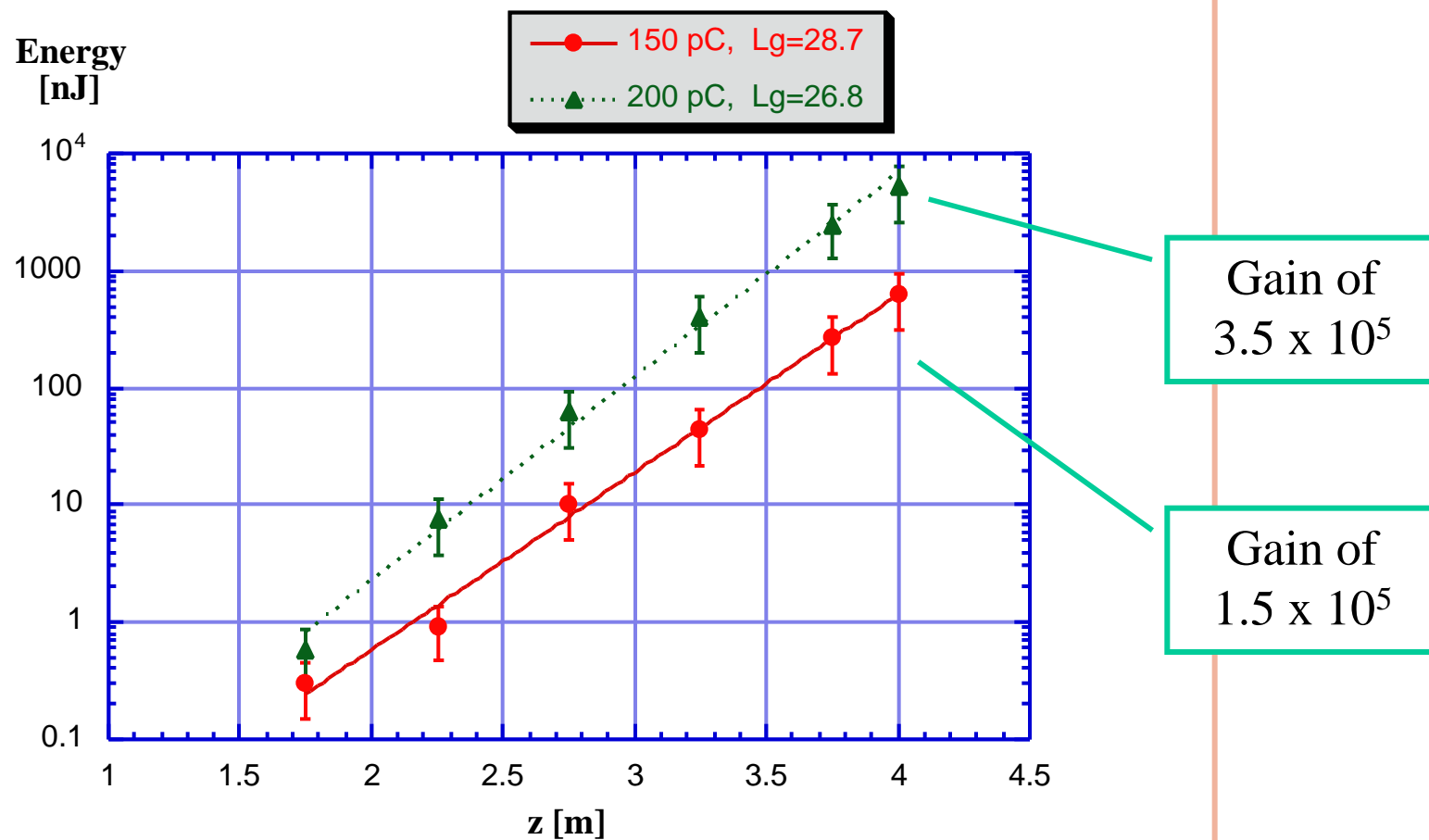

Saturation

March 15, 2001

$Q = 165 \text{ pC}$

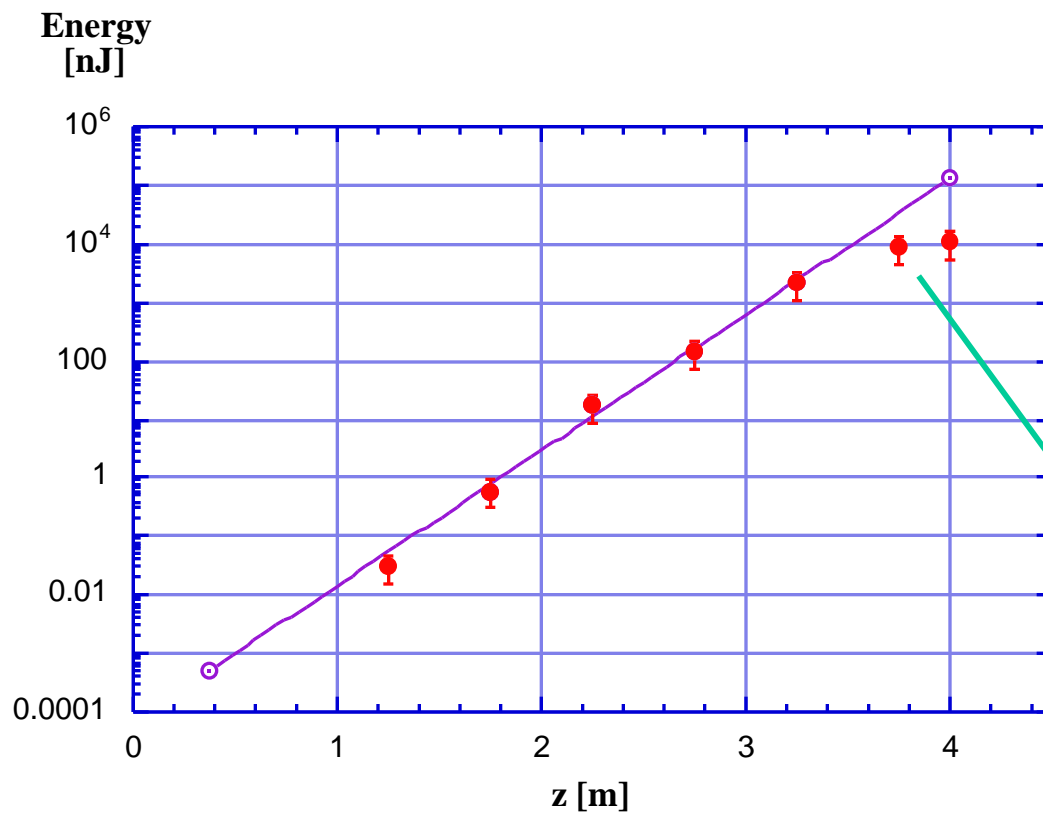

$L_g = 18.7 \text{ cm}$

$G = 2.2 \times 10^7$

Saturation at 3.6 m

Higher Charge

April 18, 2001

$Q = 290 \text{ pC}$

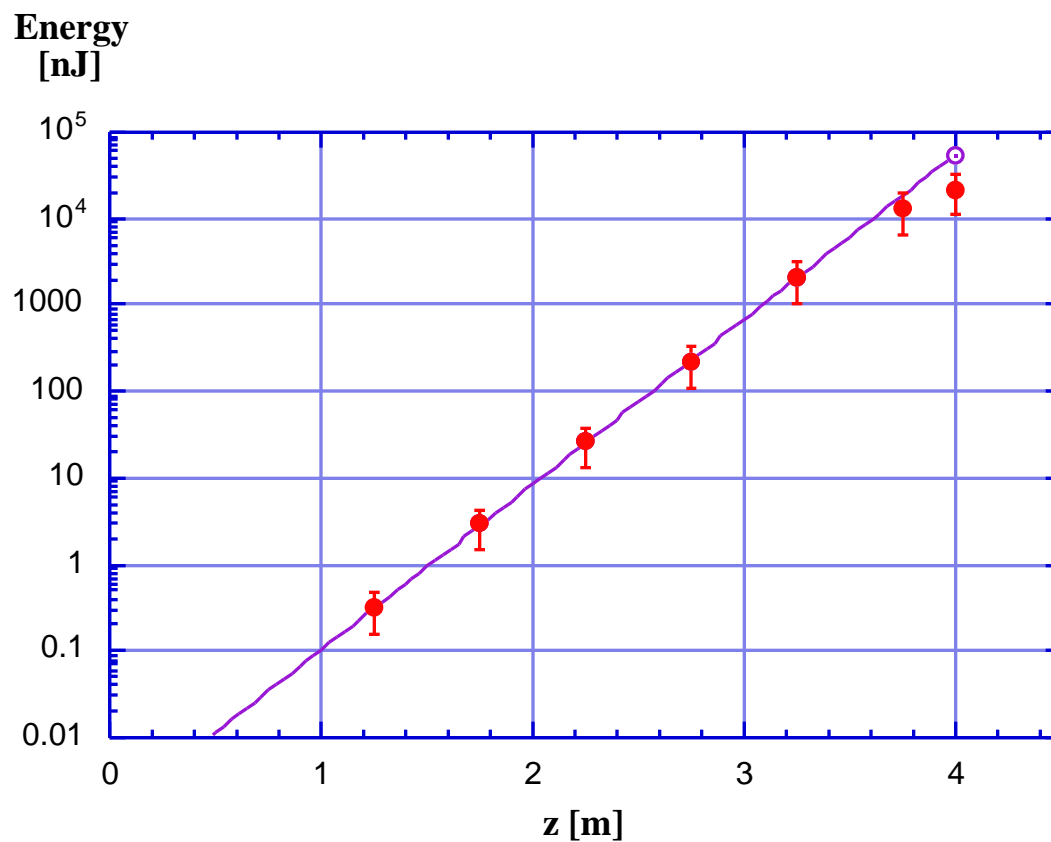

$L_g = 23.4 \text{ cm}$

$G = 2.0 \times 10^6$

Beam Parameters

Emittance [mm-mrad]

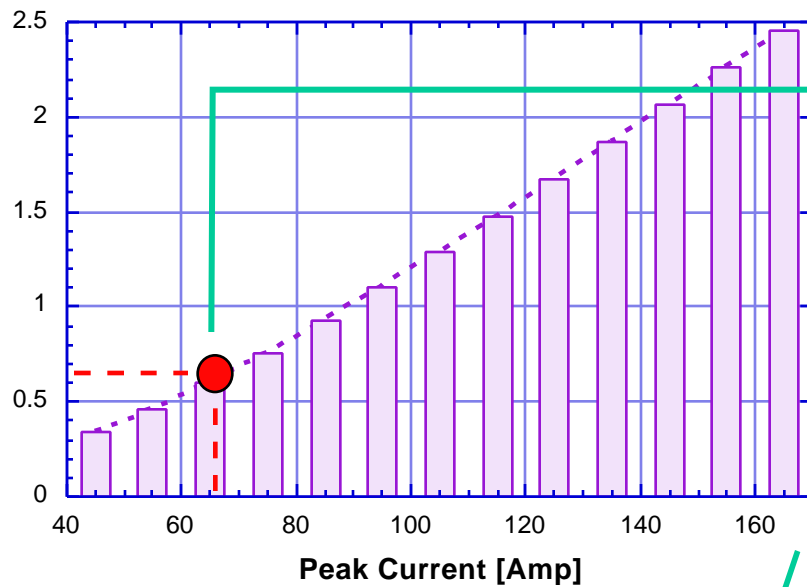

If we believe a bunchlength measurement (68 A), the beam has a sliced emittance below 0.7 mm- mrad

Beam parameters required to achieve 18.5 cm gain length ($p/p \sim 0.1\%$), calculated with M.Xie formula

Current [A]

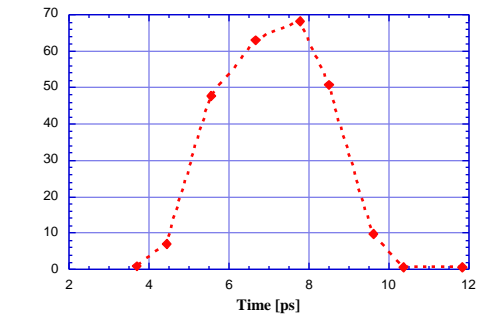

Spectrum

pop-in 4

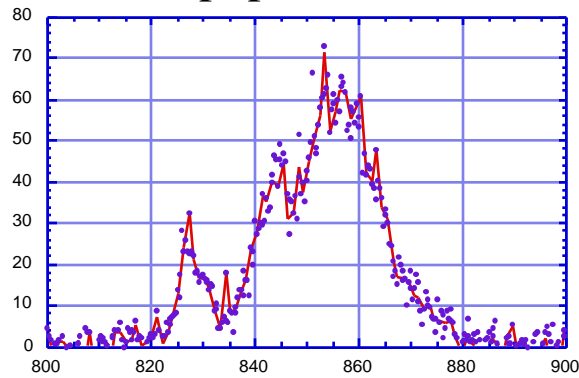

evolution along
the length



pop-in 5

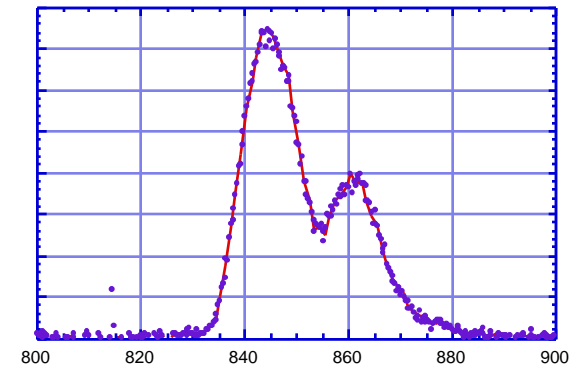

$G \sim 1000$

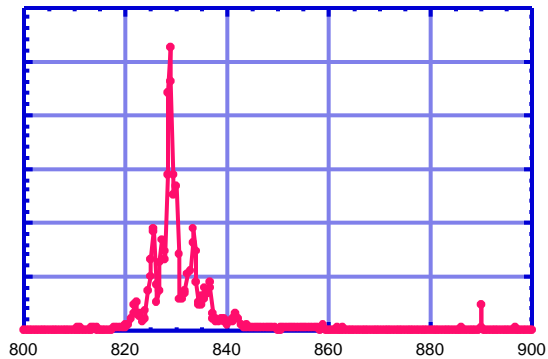

evolution along
the gain



$G \sim 10^6$

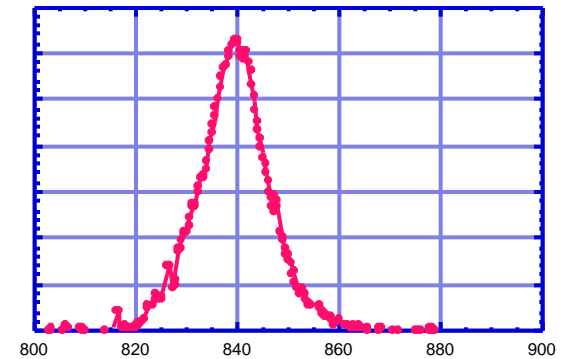

Angular Profile

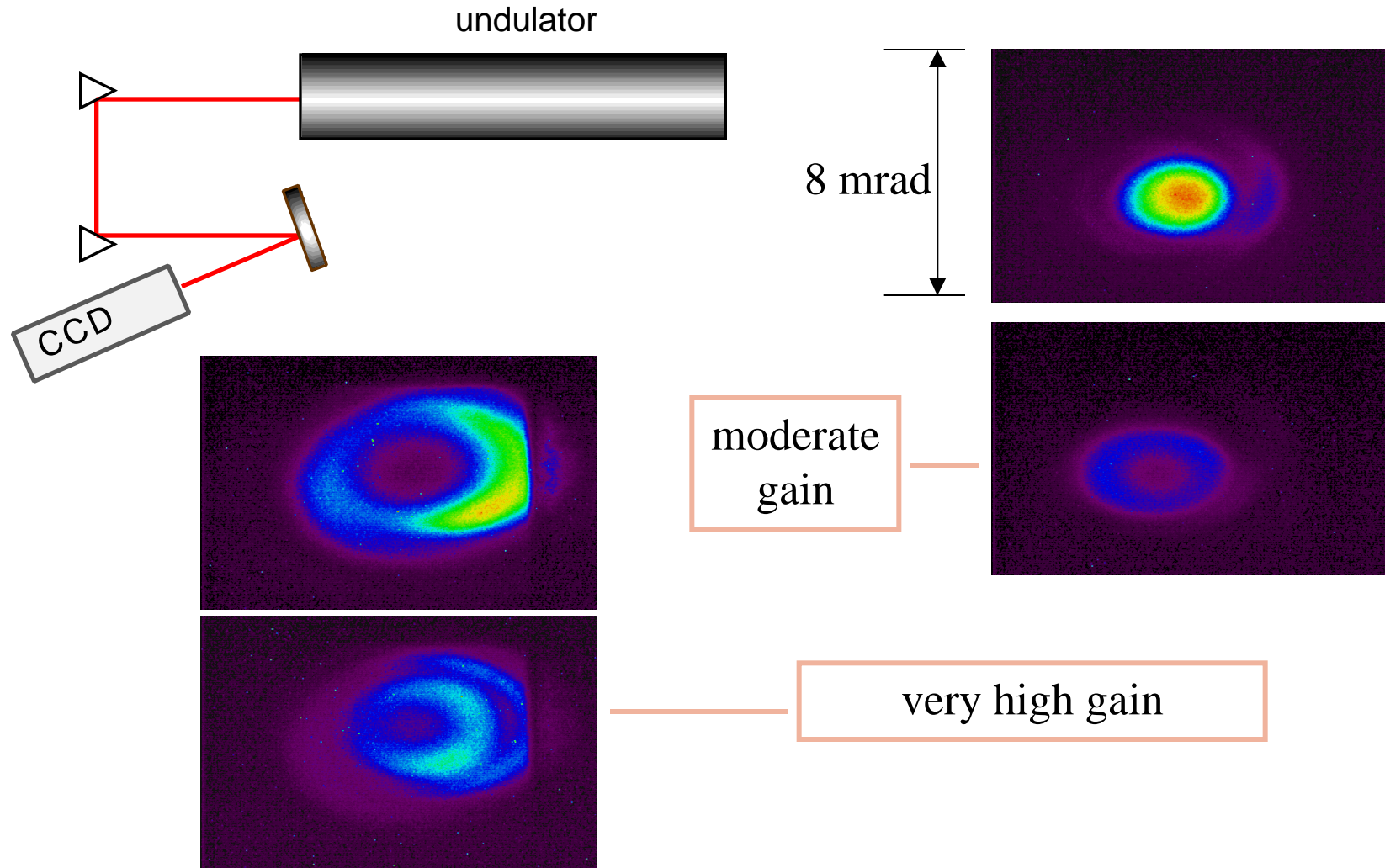

Numerical results

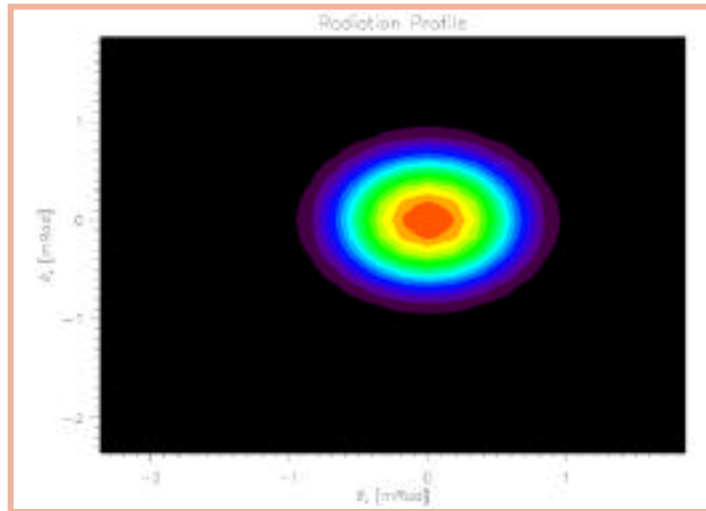

GENESIS simulations
by S. Reiche

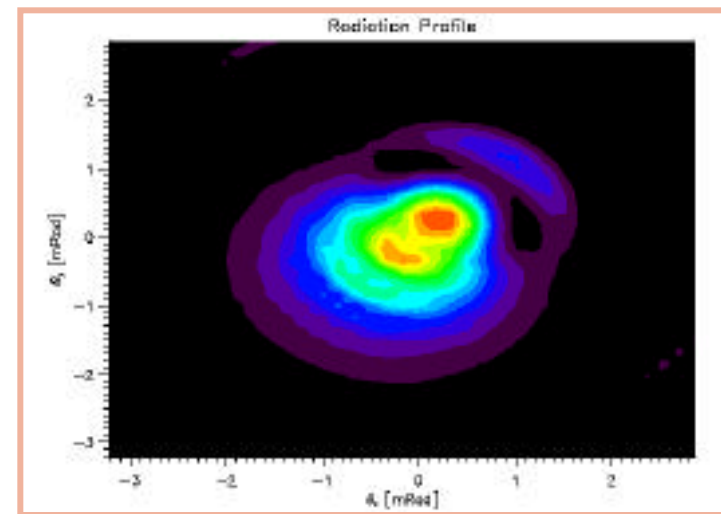

Conclusion

- VISA FEL saturation within 3.6 meter was demonstrated
- Gain length of 18.7 cm is achieved with overall gain of > 20 M
- Spectral and angular measurements are being performed

Need to be done

- Modify undulator BPMs to enable beam envelope measurements
- Complete spectral and angular measurements vs. length