

HE-SXR Undulator Test Plan

Zachary Wolf, Yurii Levashov, Heinz-Dieter Nuhn
Stanford Linear Accelerator Center

October 25, 2022

Abstract

This note presents the test plan for the HE-SXR soft x-ray undulators. The undulators will be measured and tuned in the Magnetic Measurement Facility at SLAC. The requirements of the tuning are well established and are summarized in this note. A brief discussion of the measurement equipment is presented. This is followed by the detailed test plan in which each step is enumerated. Finally, the measurement results and data storage format are presented.

1 Introduction¹

The high energy upgrade (HE) to the LCLS-II soft x-ray line (SXR) will involve tuning and calibrating 31 undulator segments (hereafter, the undulator segments will be referred to as undulators). The existing 22 undulators will have new magnet arrays installed increasing the period from 39 mm to 56 mm. Nine new undulators with the 56 mm period will be purchased. These numbers include 30 installed undulators and one spare. All 31 undulators will require tuning and calibration. This work will be done at SLAC in the Magnetic Measurement Facility (MMF). The undulators must also be fiducialized to allow alignment with other components. This note details the plan for tuning, calibrating, and fiducializing the HE-SXR undulators.

The note begins by describing the laboratories in which the work will be performed and the relevant equipment is then briefly described. The list of tuning and fiducialization requirements is presented. This is followed by a detailed test plan in which all the steps of tuning, calibration, and fiducialization are enumerated.

2 SLAC Magnetic Measurement Facility

The SLAC magnetic measurements group has two high precision measurement benches for tuning undulators and for making final data sets as discussed below. The benches are in a laboratory which has 0.1 °C temperature stability at a set point variable from 17 °C to 23 °C. Most measurements will take place at 20.0 °C, but the variable set point will allow studies of temperature effects on the undulators. The benches are located on

¹Work supported in part by the DOE Contract DE-AC02-76SF00515. This work was performed in support of the LCLS project at SLAC.

deep foundations to ensure vibration isolation and bench alignment stability. In addition, the foundations are wide enough to hold both the bench and the undulator under test in order to maintain relative alignment. Proper undulator handling infrastructure will be provided such as cranes, forklifts, smooth floors, and powered movers. Proper laboratory equipment is provided such as a light duty crane for handling support pedestals and long measurement coils, a complete set of instruments, calibration equipment, etc. Hall probe calibrations are done in the laboratory. Storage space for at least two undulators exists in an adjacent room to allow undulators to come to temperature before testing. Storage space for receiving undulators and for storing them until they are needed for installation is provided adjacent to the MMF. Storage space for the reference undulators will be provided in the main measurement laboratory.

SLAC will be responsible for storing undulators from the time they are calibrated until they are placed in the tunnel. The storage location must maintain ± 15 °C temperature stability so that the undulators are not damaged by thermal expansion effects or by demagnetization effects. The storage location must also provide humidity control and contamination control. SLAC will provide all undulator transportation on the SLAC site.

The MMF has a CMM which will be used to inspect magnet arrays when they arrive, and to align the magnet arrays on the strongbacks. The MMF also has space for a measurement bench which can do rough tuning of the undulators if the schedule requires it.

3 Undulator Measurement Precision

FEL performance relies on all undulators in the system having precise K values relative to each other. There are additional requirements, but this one is the most demanding. Small systematic errors are tolerated in the K values, as long as they are the same for all undulators in the line. To keep the systematic errors as constant as possible, all undulators in a given line will have their final data sets and fiducialization done on the same bench with the same instruments, frequent calibrations, and devices to check the consistency of the measurements. The bench used for final data sets is located in the MMF.

Having one bench perform final data set measurements is an important step in meeting the tolerances, but it is not sufficient. The bench must make both precise and accurate measurements so that if an instrument breaks, it can be replaced without affecting the measurement results. Detailed calibrations will be made at SLAC and reference magnets will be used to monitor Hall probe drifts. This plan is the same as used in LCLS-I² and LCLS-II³.

4 Earth's Field

The Earth's field is different in the tunnel than in the measurement lab. LCLS-I experience shows that differences of 0.2 G should be expected. The permeable material in the undulator

²Z. Wolf, Y. Levashov, H.-D. Nuhn, and I. Vasserman, "LCLS Undulator Test Plan", LCLS-TN-06-17, December, 2006.

³Z. Wolf, et al., "LCLS-II Undulator Test Plan", LCLS-TN-17-1 Rev 1, July, 2018.

poles will amplify this difference in the undulator gap by a factor of about 2. The difference in the Earth's field is large enough to bring the undulator field integrals out of tolerance.

In order to minimize the difference in the Earth's field between the measurement lab and the tunnel, the SLAC benches are oriented parallel to the tunnel. The tuning and final data sets will be made with the undulator in the same orientation as it will have in the tunnel. The layout of the tunnel and the laboratory is shown in figure 1.

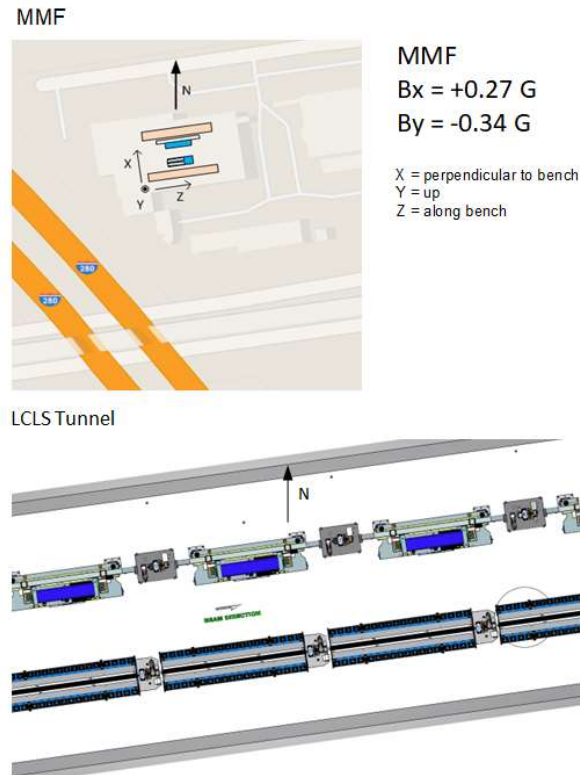

Figure 1: This figure shows the layout of the MMF and the LCLS tunnel. During tuning and calibration, the undulators must have the same orientation in the lab as in the tunnel.

To account for the expected 0.2 G difference between the MMF and the tunnel, a Helmholtz coil will be set up in the MMF. One or more undulators will be put in the Helmholtz coil and the field integrals will be measured as a function of applied field. The applied field simulates the field difference between the MMF and the tunnel.

The Earth's field difference will be corrected by correction coil windings on the beam pipe. The corrector current settings will be calibrated in the MMF. The Earth's field in the tunnel will be mapped and compared to the Earth's field in the measurement lab for each undulator location. In this way, the corrector current settings will be determined for each undulator location.

5 Undulator Tuning Requirements

The LCLS-II-HE undulator calibration and fiducialization requirements come from an undulator Physics Requirements Document⁴. The list of tuning and fiducialization requirements are briefly summarized below.

5.1 HE-SXU Requirements

The undulator will be primarily tuned at a tuning gap of 10 mm, but the requirements must be met for all gaps in the operating range of 7.2 to 33 mm. The field integral tolerances given below must be met for all horizontal and vertical positions within ± 1.0 mm of the undulator beam axis. The K value and phase tolerances must be met on the undulator beam axis.

1. The K value must be known to $\pm 5.5 \times 10^{-4}$ at all gap settings. The K value will be measured at a discrete set of gaps. A fit to the measured K value vs. gap data must allow K values at intermediate points to be known within the tolerance given here. This requirement sets the density of the measurements as a function of gap.
2. The phase shake in each undulator must be less than 5 degrees rms.
3. The total phase advance in the 4.400000 meter long cell must be known to ± 10 degrees.
4. The phase matching error at both the entrance and the exit of the undulator must be known to ± 7 degrees.
5. The first field integral of B_x and B_y must be within $\pm 50 \times 10^{-6}$ Tm. The second field integral of B_x and B_y must be within $\pm 200 \times 10^{-6}$ Tm².
6. The undulator temperature at which all measurements are performed must be 20.0 ± 0.1 degrees Celsius.
7. The position of the undulator beam axis must be within ± 500 μm in x and ± 150 μm in y of the electron beam trajectory in the tunnel.

5.2 Operational Requirements

We impose the following operational requirements.

1. The reference undulator must be measured and fiducialized after every 4'th undulator. At this time, the alignment of the measurement bench must also be checked.
2. A reference magnet at the bench must be measured with the Hall probe and this measurement compared to an NMR measurement before each final data set. The Hall probe must be recalibrated when its measurement relative to the NMR changes by more than 1×10^{-4} .

⁴D. Cesar et al., "LCLS-II-HE SXR Undulator System Physics Requirements", LCLSII-HE-1.3-PR-0049-R2, May, 2022.

3. No magnetic shield will be used on the undulators. A Helmholtz coil must be set up to study the effect of changes in the Earth's field between the laboratory and the tunnel.
4. A corrector on the beam pipe must be characterized to determine the current settings required to correct the differences in the Earth's field as the gap is changed.
5. A tuning gap of 10.0 mm is chosen to minimize rms phase errors.
6. A commissioning K value of 4.29 was chosen based on the first article measurements. At the commissioning gap, phase matching shims will be inserted at the undulator ends in order to make the phase matching error less than ± 5 deg modulo 360 deg at the entrance and exit ends. In this way, the undulator lines can be commissioned with the phase shifters off.
7. After tuning, the undulators will be stored until they are placed in the tunnel. Every four months, an undulator must be returned from storage and inspected and measured to verify that the storage conditions are not altering the undulator. Temperature and humidity must be logged in the undulator storage area.
8. Before all undulators are measured, one undulator will be used for a temperature test. The K value will be measured over the range 18 °C to 22 °C in 1 °C steps. These measurements will be used to determine corrections to the gap settings for tunnel temperatures different than 20.0 °C.
9. One undulator will be transported to the LCLS-II tunnel and then returned to the MMF for re-measurement. This test is to ensure that undulator handling practices do not change the K calibration.

5.3 Measurement Requirements

The measurement bench will use a touch probe to align the undulator to the bench. Hall probes will be used for most of the magnetic measurements. A long coil or flip coil with small loop area (< 3 mm) will be used for overall field integral and field uniformity measurements. The undulator fiducialization will occur at the bench using a laser tracker. Sets of fiducialization magnets and reference poles on stands at the ends of the undulator will be used as checks to avoid fiducialization errors. Optical alignment equipment will be used to check the fiducialization. A vertical field alignment magnet is used to set the probe angles. A reference magnet is used to check the Hall probe calibration. The touch probe will be used to give mechanical gap measurements at each pole for a set of gap encoder readings.

Each Hall probe measurement starts in a zero Gauss chamber and ends in a zero Gauss chamber. There is minimal field in these chambers, so any non-zero reading is due to offsets in the probe electronics. A linear fit is made to the beginning and end measurements in the zero Gauss chambers and the fit is subtracted from the measurements in the undulator as a zero offset correction.

6 Tuning, Calibration, and Fiducialization Test Plan

6.1 Overview

The undulator tuning, calibration, and fiducialization is done in several stages. When an undulator is delivered to the MMF, an acceptance test will be performed. In addition to the acceptance test, all limit switch settings will be made and all encoder offset values will be determined so that the undulator is protected and operational when it is moved into the lab for tuning. Before tuning, the undulator must sit in a temperature stabilization area for at least two days. For tuning, the undulator is brought to a bench and aligned. Measurements are made at the tuning gap and other gaps and an algorithm from LBNL may be used to choose different shim types to minimize the field integrals at all gaps. Phase errors will be minimized at the tuning gap. After the tuning, the gap is changed to give the commissioning K value, and phase matching shims are added at the ends so that the phase shifters can be turned off when K has this value. The gap is then varied and the undulator parameters are measured as a function of gap. When the tolerances are met at all gaps, a final data set will be made and the undulator will be fiducialized.

6.2 Test Plan

1. Preliminaries
 - (a) All undulators must have their limit switch positions set and their encoder offsets set before entering the tuning laboratory. The undulator must be protected and functional.
 - (b) The undulator must be at 20 ± 0.5 °C when it is moved to the bench. During the setup time and initial tuning, the undulator must come to a temperature of 20 ± 0.1 °C.
 - (c) CMM measurements will be done on the magnet modules when they arrive at SLAC. Touch probe measurements will be made at the measurement bench before tuning starts. These mechanical measurements verify that the undulator components are positioned properly for the tuning to begin.
2. Place the undulator
 - (a) Bolt the HE-SXR undulator to the floor at the SXR measurement bench.
 - (b) Make all necessary wiring connections to operate the undulator. Test all limit switches.
 - (c) Attach thermistors to measure temperature.
3. Mechanically align the undulator to the bench
 - (a) Set the undulator gap to the tuning gap value.
 - (b) Have an alignment crew align the undulator to the bench. The probes must go through without touching.

- (c) Use capacitive sensors or a touch probe to measure the undulator position, pitch, yaw, and taper.
 - (d) Use the position adjustments to move the undulator into final position. At this point, the mechanical center line is 1.4 meters above the floor and it is at a fixed location away from the bench all the way down the bench.
4. Mechanically straighten the undulator poles
- (a) Measure the straightness of the undulator poles on each jaw using either capacitive sensors or a touch probe.
 - (b) By either moving poles or by shimming the pole assemblies, straighten the magnet poles on each jaw so they are in a line to within $\pm 20 \mu\text{m}$.
 - (c) Record the pole positions at the tuning gap.
5. Magnetically align the Hall probe to the undulator
- (a) Set the undulator gap to the tuning gap.
 - (b) Measure along the undulator with the Hall probe to find the pole positions.
 - (c) At every N 'th pole ($N \simeq 3$), move the Hall probe in x and y and find the magnetic center. Alternatively, perform scans at several x and y locations and determine the magnetic center at each pole from the scans. Fit the magnetic field centers as a function of z . Move the probe to the field center line.
 - (d) Correct the pitch of the magnetic center line using encoder offsets. Correct the yaw of the magnetic center line with the position adjustments. If necessary, repeat step (c).
 - (e) The magnetic center line defines $x = 0$, $y = 0$ for the Hall probe position. This line will be the beam axis.
 - (f) Make a Hall probe scan on the magnetic center line. Check for taper in the magnetic field peaks. If necessary, take out the taper using the gap encoder offsets.
6. Magnetic field tuning
- Tune the field integrals, the x trajectory, y trajectory, and the phase. LBNL software can be used to choose shim combinations and shim positions based on several measurements at different gaps and different x -positions. The measurement gaps and x -positions are determined by the LBNL staff based on the undulator parameters. The software specifies shim types and shim locations. Where pole motions are specified, use capacitive sensors to monitor and record the pole motions. Minimize peak field scatter at the tuning gap below 0.25% in order to minimize phase errors. Minimize phase errors at the tuning gap.
7. Check the gap dependence of the tuning
- (a) Check the trajectory straightness and phase errors at gaps ranging from the minimum gap to the maximum operating gap in steps of 2 mm.

- (b) If the trajectories are not straight or the phase errors grow out of tolerance at gaps other than the tuning gap, repeat step 6 until the trajectory and phase shake tolerances are met at all gaps in the operating range.
8. Check the gap dependence of the field integrals
 - (a) Set up the long coil or flip coil at $x = 0, y = 0$.
 - (b) At a set of gaps, measure the field integrals of both B_x and B_y with a long coil or flip coil.
 - (c) Use trajectory shims with the appropriate gap signature at the entrance to null the second field integrals.
 - (d) Use trajectory shims with the appropriate gap signature at the exit to null the first field integrals.
 - (e) Repeat these steps in an iterative way until the field integrals are within tolerance at all gaps in the operating range.
 9. Check the field integral uniformity
 - (a) At the tuning gap, use the long coil to measure the field integrals at $y = 0$ as a function of x at $x = -1, -0.5, 0, 0.5, 1$ mm.
 - (b) Use quadrupole, skew quadrupole, and sextupole shims to bring those terms within tolerance. This step is also addressed as part of the magnetic field tuning step.
 - (c) Measure the field integrals at $x = 0$ as a function of y at $y = -1, -0.5, 0, 0.5, 1$ mm.
 - (d) Use skew quadrupole and skew sextupole shims to bring those terms within tolerance. If skew quadrupole and skew sextupole shims are not available and the field integrals are out of tolerance, consult the undulator system physicist.
 - (e) Repeat these steps in an iterative way until the field integrals are within tolerance at all gaps in the operating range.
 10. Check the K uniformity
 - (a) With the Hall probe, measure the K value at $y = 0, x = -1.0, -0.5, 0, 0.5, 1.0$ mm and $x = 0, y = -0.50, -0.25, 0, 0.25, 0.50$ mm.
 - (b) Verify that the second derivative of K vs position meets the falloff tolerance. If this condition is not met, consult the undulator system physicist.
 11. Find the commissioning gap

After the tuning is done, measure at several gaps near the gap which gives the commissioning K value of 4.29. Fit the measurements and determine the gap which gives the commissioning K value.
 12. Add phase matching shims

- (a) Set the gap to the value which gives the commissioning K value. Measure and calculate the phase advance from the middle of the break section to each of the poles from the 7th pole at the entrance to the 7th pole from the exit. Subtract the ideal phase at each pole⁵. Average to find the phase matching error over these poles. Add phase matching shims at the entrance to make the phase matching error modulo 360 deg smaller than ± 5 deg. Repeat the measurement to verify that the phase matching at the entrance is correct.
- (b) Measure and calculate the phase advance in the cell, defined from the center of the interspace region preceding the undulator to the center of the interspace region after the undulator. Add phase matching shims at the exit to give the cell phase its ideal value⁶ within ± 5 deg.

13. Final checks

- (a) Check the x trajectory, y trajectory, and the phase at gaps of 7.5, 9.0, 11.0, 13.0, 17.0, 25.0, 33.0 mm. Correct if necessary.
- (b) Check for taper in the peak fields at the tuning gap. Correct if necessary.
- (c) Check the phase matching at the commissioning gap. Correct if necessary.
- (d) Check the first and second field integrals of B_x and B_y at gaps of 7.5, 9.0, 11.0, 13.0, 17.0, 25.0, 33.0 mm. Correct if necessary.
- (e) If corrections were done, repeat the checks.
- (f) Check the gap with a clearance gauge to make sure no shim or pole is protruding into the gap. Fix problems as necessary.
- (g) Check for pitch of the gap. Correct if necessary.

14. Final results data set

- (a) Measure the field integrals in the good field region. Use the long coil to measure the first and second field integrals of B_x and B_y . Measure from $x = -1$ mm to $x = +1$ mm in 0.5 mm steps with $y = 0$. Measure from $y = -1$ mm to $y = +1$ mm in 0.5 mm steps with $x = 0$. Repeat this at gaps of 7.2, 8, 9, 10, 11, 12, 13, 14, 16, 18, 20, 22, 24, 27, 30, 33, 40, 50, 60, 80, 100, 120, 140, 160, 180 mm. Place the data in the final results folder.
- (b) Measure the field integrals on the undulator axis. Use the long coil to measure the first and second field integrals of B_x and B_y . Measure at $x = 0$, $y = 0$. Measure at gaps of 7.2, 8, 9, 10, 11, 12, 13, 14, 16, 18, 20, 22, 24, 27, 30, 33, 40, 50, 60, 80, 100, 120, 140, 160, 180 mm. Place the data in the final results folder.
- (c) Measure the uniformity of the K value. With the Hall probe, measure the K value at $y = 0$, $x = -1.0, -0.5, 0, 0.5, 1.0$ mm and $x = 0$, $y = -0.50, -0.25, 0, 0.25, 0.50$ mm. Repeat this at gaps of 7.2, 8, 9, 10, 11, 12, 13, 14, 16, 18, 20, 22, 24, 27, 30, 33, 40 mm. Place the data in the final results folder.

⁵Z. Wolf, "Phase Matching The LCLS-II Undulators", LCLS-TN-16-3, July, 2016.

⁶Ibid.

- (d) Make Hall probe measurements on the undulator axis to record the phase shake, to fit K and the phase matching requirements, and to record the field integrals over the cell length. Perform measurements at $x = 0, y = 0$ mm at gaps of 7.2, 7.50 to 11.0 mm in steps of 0.25mm, from 11.0 to 33.0 mm in steps of 0.5 mm, at 34, 35, 40, 50, 60, 80, 100, 120, 140, 160, 180 mm, and then closing the gap from 33.0 to 11.0 mm in steps of 0.5 mm, from 11.0 to 7.5 mm in steps of 0.25 mm, and finally at 7.2 mm. Correct all Hall probe measurements using the first and second integral values measured with the long coil. Determine the K value at each gap setting in the operating range. Verify that the fit to the K value vs gap measurements allows one to determine K at all gap settings in the operating range to better than 10^{-4} based on the residuals. Verify that the fit to the phase matching data allows one to determine the phase matching settings to better than 1 degree based on the residuals. The density of this data set may change based on measurements in the first few undulators. Verify that the phase shake is within tolerance at all gap settings in the operating range. Verify that the first and second field integrals over the cell length are within tolerance at all gap settings. Verify that hysteresis in the K value is within the K value tolerance. Place the data in the final results folder.
- (e) Make Hall probe measurements on the undulator axis to record the commissioning gap. Perform measurements at $x = 0, y = 0$ mm at gaps of 15.0, 15.5, 16.0, 16.5, 17.0, 17.5, 18.0 mm. Perform a fit to determine the commissioning gap which gives $K = 4.29$. Perform a measurement at the commissioning gap. Document that the entrance and exit phase matching errors are a multiple of 360° . Place the data in the final results folder.
- (f) Make Hall probe measurements on the undulator axis to record the field when the undulator is tapered. Perform measurements at $x = 0, y = 0$ mm at gaps of 10.0, and 20.0 mm with a taper of +0.100, +0.300, -0.100, 0.000 mm. Place the data in the final results folder.
- (g) Place all undulator operating parameters, such as encoder offsets, in a file in the final results folder. All operating parameters must also be included in each measurement file.
- (h) Using capacitive sensors, record the gap, encoder readings, and pole number at several poles at each end of the undulator in order to allow encoder replacement in the tunnel. Place the data in the final results folder.
- (i) Make files containing data for spline fits to be used by the control system to operate the undulator. The required files provide data for K vs gap, entrance phase matching vs gap, exit phase matching vs gap, midplane height shift vs gap, I_{1x} vs gap, I_{1y} vs gap, I_{2x} vs gap, and I_{2y} vs gap. I_{1x} refers to the first integral of the B_x field, I_{2x} refers to the second integral, etc. Place these files in the final results folder.

15. Fiducialization

- (a) The fiducialization magnets are permanently on the stands at the ends of the SXR undulator.

- (b) Measure the offset from the beam axis to the center of the fiducialization magnets.
- (c) Perform this measurement at both ends of the undulator.
- (d) Have the alignment crew locate the tooling balls on the fiducialization magnets and on the undulator using a laser tracker.
- (e) Fiducialize the undulator in z by locating the poles at each end of the undulator either using a laser tracker or the CMM. Define the mechanical center of the undulator in z as the average of the z -positions of the end poles. Relate the mechanical center to the tooling balls.
- (f) Place fiducialization data in the final results folder.

16. Fiducialization check

Perform fiducialization checks using manual alignment equipment, touch probe measurements, and/or redundant laser tracker measurements. These checks must include comparing the magnetic axis location to the mechanical center of the undulator. Document the checks in the final results folder.

17. Touch probe measurements

At the tuning gap, perform touch probe measurements to record the mechanical gap at each pole. Repeat with the undulator tapered by +0.100, +0.300, -0.100 mm. Put these results in the final results folder.

7 Measurement Results

All raw data and analysis results will be available from the SLAC web site. The data will be stored in a directory structure as show in figure 2. The top level directory is *Magdata*, followed by *LCLS-II-HE*, followed by the magnet type *Undulator*. In the *Undulator* directory, there is a folder for each undulator named by the serial number. For the HE-SXR undulators, the serial number has the format HE_SXU_nnn. For refurbished SXR undulators, the SXU_nnn part of the name is unchanged from its LCLS-II value. For each undulator, *Dataset* directories are made. When the undulator comes back for multiple measurements over time, each set of measurements goes into a new dataset. Within each dataset, the *Mechanical Measurements*, *Tuning*, and *Final Results* folders are created. Each contains all the relevant measurements. For instance, the contents of the Tuning folder are shown in figure 3. Multiple runs are required and the data and analysis results from each run will go into a run folder. An index file will give a description of each run. Within a run, multiple measurements may be made. For Hall probe scans, each measurement and its analysis results will go into a folder whose name is determined by the measurement number, the gap, and the x and y probe positions for the measurement. The fixed width format is "nnngapnnn.nnnxsnn.nmysnn.nn", where "s" represents a sign, "." represents a decimal point, and "n" is a decimal digit. The initial "nnn" is used to give the measurement number. The gap and probe positions are in millimeters. All data files will be text files. All Hall probe measurement data files will be called "zscan.dat". In this way the analysis programs can be more easily automated so the contents of a folder are known in advance. Analysis results will be in both text files and either postscript plot files

or PDF plot files. For long coil or flip coil measurements, a similar scheme is used. A run folder contains multiple measurements. Each measurement produces data files with format "nnngapnnn.nnnxsnn.nnysnn.nn_qqq_tt". The first part of the data file name, up to the first underscore, contains the measurement number, the gap, and the x and y coil position, using the same format as the Hall probe scans. After the first underscore, "qqq" describes the quantity being measured and will be either "i1x", "i2x", "i1y", or "i2y" for the first or second field integrals of B_x or B_y . The "tt" refers to a file type descriptor. Summaries of the field integral measurements are provided in a file called "integrals_summary.txt".

The mechanical measurements folder contains measurements from a touch probe or other device characterizing the mechanical properties of the undulator.

Capacitive sensor data will include a file containing the z position and all measured distances from the sensors. Another file will contain the calculated undulator pole position and orientation.

Align-x and Align-y data include files from scanning the Hall probe in x and y and finding the magnetic center. This is done at a number of poles down the undulator. Alternatively, scans at various x and y locations may be used.

The z -scan magnetic measurement data will consist of columns of the z positions, the V_x and V_y Hall probe voltages, and B_x and B_y values. Parameters, such as the Hall probe calibration file, will be included in a header. Two separate analysis programs will be run on the data. The first computes the trajectories, phase, etc. The second computes the shims required to tune the undulator. These programs output text files containing the results and also plots in postscript or PDF files or Matlab figure files.

The long coil data will consist of the (x, y) location of the coil, parameters of the coil motion, the integrated voltage, and the first and second field integrals. Multiple measurements will be done. Each measurement will be recorded and the average and rms deviation will be provided. Output files will be text files containing a header and the first and second integrals of B_x and B_y .

When long coil or flip coil measurements are associated with a particular Hall probe scan in order to correct Hall probe offsets, the coil data may be placed in the folder with the associated Hall probe measurement.

After the tuning runs are complete, a special set of final measurement runs is made. The analysis results from these runs will go into a "Final Results" folder. The contents of the "Final Results" folder are shown in figure 4.

The fiducialization data will be put in its own folder. The data comes from several sources: scale readings from the measurement bench, offsets between the center of the fiducialization magnets and tooling balls, laser tracker data, and alignment crew data. All files will be text files containing a header and the measured values. A program will read the data and write a fiducialization report containing the final results.

The "Gap Measurements" folder contains touch probe measurements of the gap at fixed encoder readings. These measurements will be useful if the undulator is remeasured and magnetic effects are to be distinguished from mechanical effects. The "Gap Measurements" folder also contains gap measurements using capacitive sensors. These measurements will allow gap encoder replacement in the tunnel.

The "Controls Data" folder contains files needed to operate the undulator. Each file has the serial number both in the contents of the file and in the file name. The Controls group

will put the contents of these files into their database. The files contain the undulator parameters used during testing, and a set of data for spline fits relating K , the phase matching corrections, the field integrals, and the midplane center height, all to the undulator gap.

8 Summary

SLAC will perform the LCLS-II-HE undulator tuning, calibration, and fiducialization measurements. SLAC will use one measurement bench. The Earth's field will be properly taken into account by tuning undulators in the same orientation they will have in the tunnel, performing Helmholtz coil measurements, and by a set of measurements in the tunnel which will determine small corrections to the laboratory measurements. A calibration will be performed to determine the temperature dependence of K . A transportation test to the tunnel will also be performed.

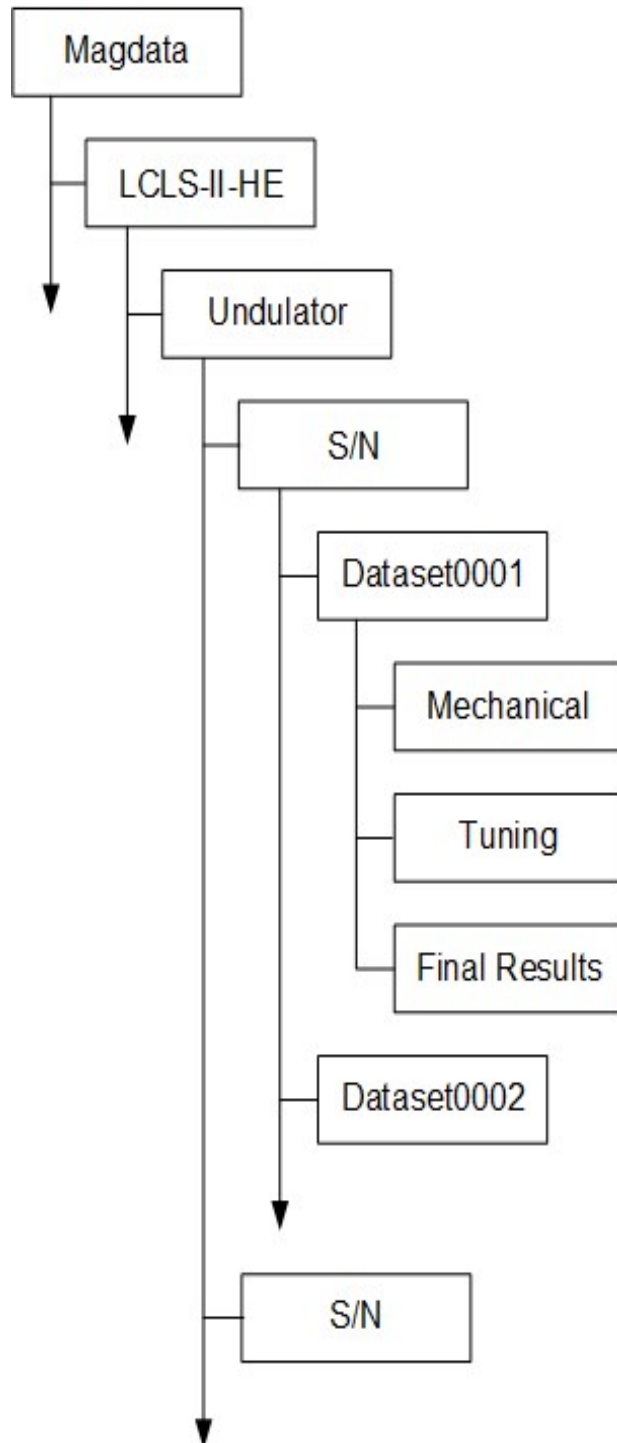

Figure 2: The undulator measurement data will be stored in a directory structure.

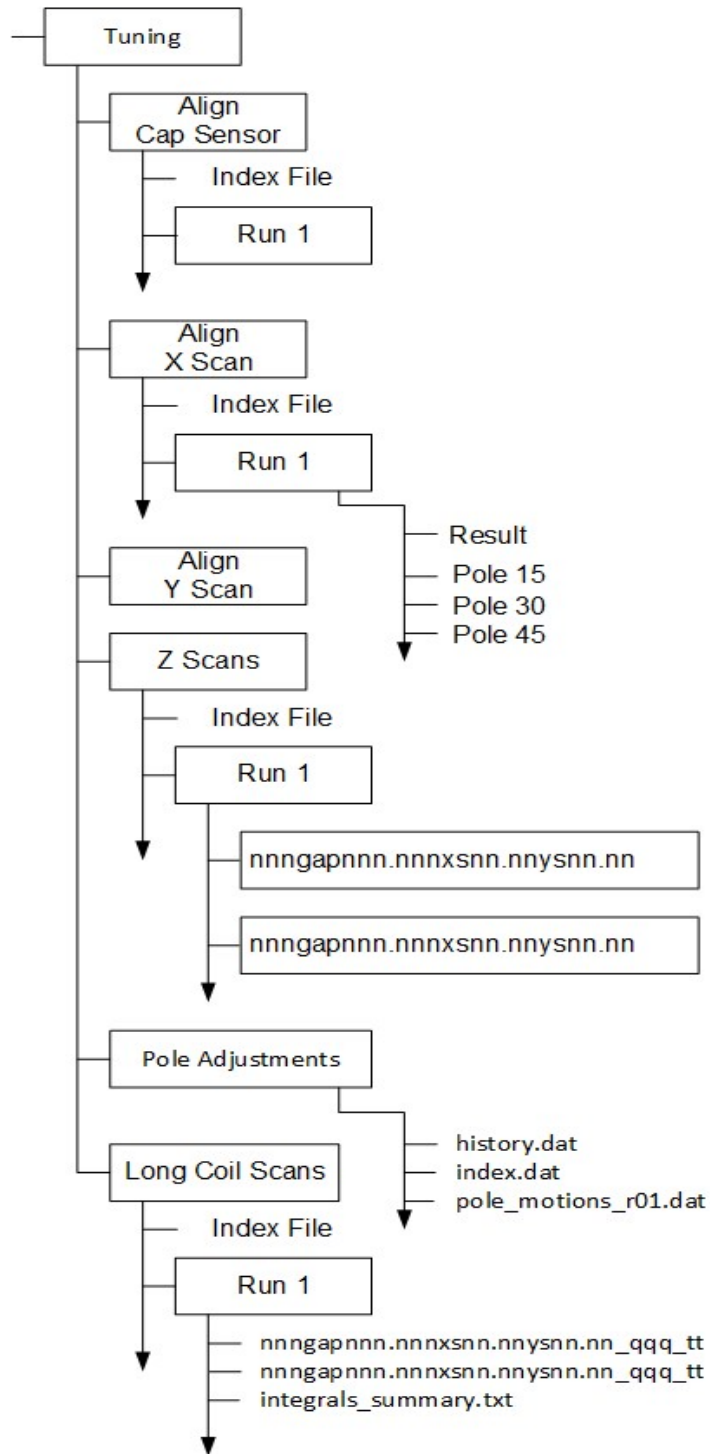

Figure 3: Contents of the Tuning folder.

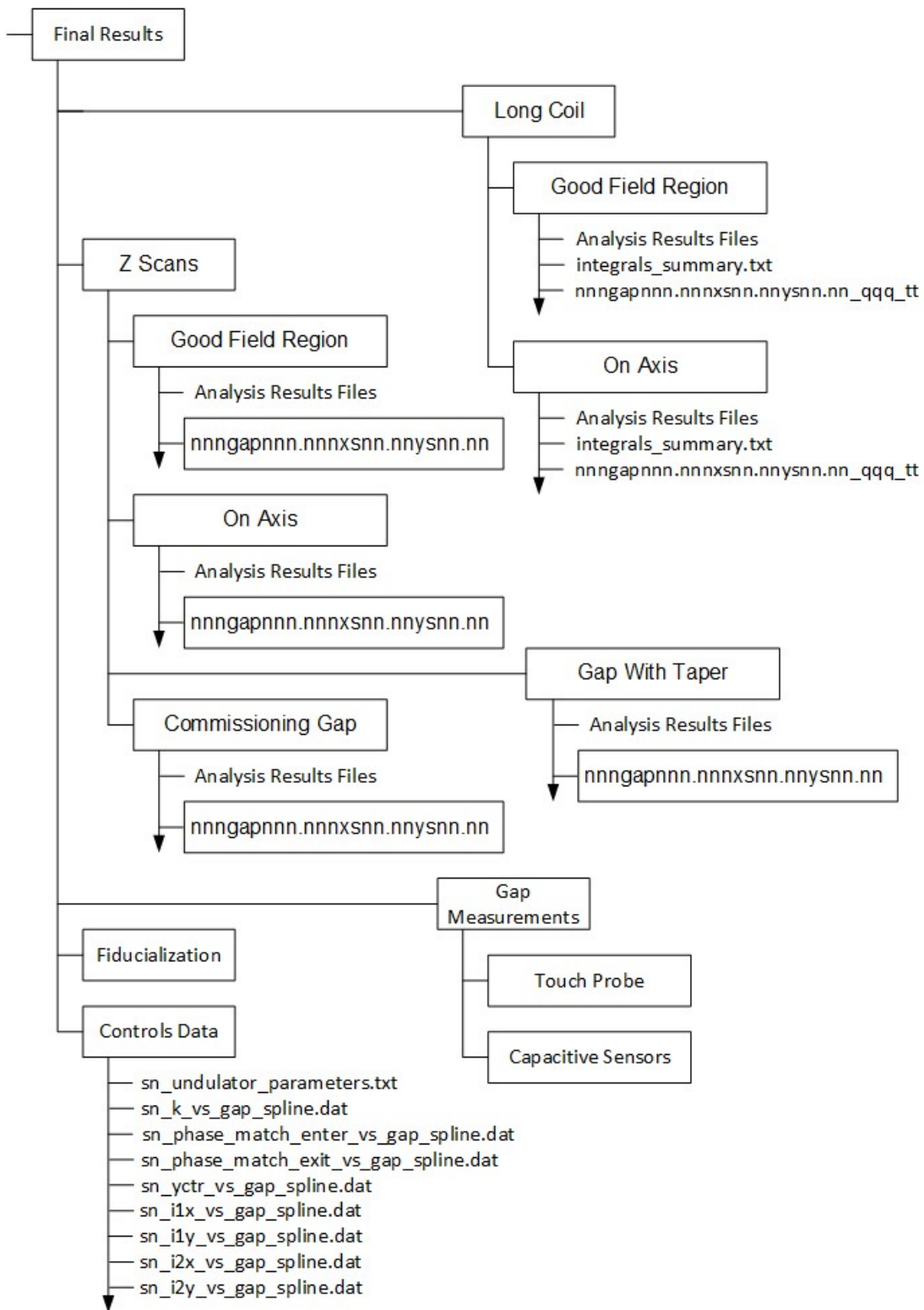

Figure 4: Contents of the Final Results folder.